

# PHILIPS

Data handbook



Electronic  
components  
and materials

## Components and materials

Part 13

July 1982

### Fixed resistors



# COMPONENTS AND MATERIALS

PART 13 - JULY 1982

FIXED RESISTORS

GENERAL A

FIXED RESISTORS B

INDEX OF CATALOGUE NUMBERS C





---

## DATA HANDBOOK SYSTEM

Our Data Handbook System is a comprehensive source of information on electronic components, sub-assemblies and materials; it is made up of four series of handbooks each comprising several parts.

ELECTRON TUBES	BLUE
SEMICONDUCTORS	RED
INTEGRATED CIRCUITS	PURPLE
COMPONENTS AND MATERIALS	GREEN

The several parts contain all pertinent data available at the time of publication, and each is revised and reissued periodically.

Where ratings or specifications differ from those published in the preceding edition they are pointed out by arrows. Where application information is given it is advisory and does not form part of the product specification.

If you need confirmation that the published data about any of our products are the latest available, please contact our representative. He is at your service and will be glad to answer your inquiries.

---

This information is furnished for guidance, and with no guarantee as to its accuracy or completeness; its publication conveys no licence under any patent or other right, nor does the publisher assume liability for any consequence of its use; specifications and availability of goods mentioned in it are subject to change without notice; it is not to be reproduced in any way, in whole or in part without the written consent of the publisher.

---

## ELECTRON TUBES (BLUE SERIES)

The blue series of data handbooks is comprised of the following parts:

- T1** Tubes for r.f. heating
- T2** Transmitting tubes for communications
- T3** Klystrons, travelling-wave tubes, microwave diodes
- ET3** Special Quality tubes, miscellaneous devices (will not be reprinted)
- T4** Magnetrons
- T5** Cathode-ray tubes  
Instrument tubes, monitor and display tubes, C.R. tubes for special applications
- T6** Geiger-Müller tubes
- T7** Gas-filled tubes  
Segment indicator tubes, indicator tubes, dry reed contact units, thyratrons, industrial rectifying tubes, ignitrons, high-voltage rectifying tubes, associated accessories
- T8** Picture tubes and components  
Colour TV picture tubes, black and white TV picture tubes, colour monitor tubes for data graphic display, monochrome monitor tubes for data graphic display, components for colour television, components for black and white television and monochrome data graphic display
- T9** Photo and electron multipliers  
Photomultiplier tubes, phototubes, single channel electron multipliers, channel electron multiplier plates
- T10** Camera tubes and accessories, image intensifiers
- T11\*** Microwave components and assemblies

\* Will become available in the course of 1982.

## SEMICONDUCTORS (RED SERIES)

The red series of data handbooks is comprised of the following parts:

- S1 Diodes**  
Small-signal germanium diodes, small-signal silicon diodes, voltage regulator diodes (< 1,5 W), voltage reference diodes, tuner diodes, rectifier diodes
- S2 Power diodes, thyristors, triacs**  
Rectifier diodes, voltage regulator diodes (> 1,5 W), rectifier stacks, thyristors, triacs
- S3 Small-signal transistors**
- S4 Low-frequency power transistors and hybrid IC modules**
- S5 Field-effect transistors**
- S6 R.F. power transistors and modules**
- S7 Microminiature semiconductors for hybrid circuits**
- S8 Devices for optoelectronics**  
Photosensitive diodes and transistors, light-emitting diodes, displays, photocouplers, infrared sensitive devices, photoconductive devices.
- S9 Taken into handbook T11 of the blue series**
- S10 Wideband transistors and wideband hybrid IC modules**

## INTEGRATED CIRCUITS (PURPLE SERIES)

The purple series of data handbooks is comprised of the following parts:

- IC1** Bipolar ICs for radio and audio equipment
- IC2** Bipolar ICs for video equipment
- IC3\*** Digital ICs for radio, audio and video equipment
- IC4** Digital integrated circuits  
LOC MOS HE4000B family
- IC5** Digital integrated circuits – ECL  
ECL10 000 (GX family), ECL100 000 (HX family), dedicated designs
- IC6\*** Professional analogue integrated circuits
- IC7** Signetics bipolar memories
- IC8** Signetics analogue circuits
- IC9\*** Signetics TTL circuits

\* These handbooks will be available in the course of 1982.



## COMPONENTS AND MATERIALS (GREEN SERIES)

The green series of data handbooks is comprised of the following parts:

- C1 Assemblies for industrial use**  
PLC modules, PC20 modules, HNIL FZ/30 series, NORbits 60-, 61-, 90-series, input devices, hybrid ICs, peripheral devices
- C2 FM tuners, television tuners, video modulators, surface acoustic wave filters**
- C3 Loudspeakers**
- C4 Ferroxcube potcores, square cores and cross cores**
- C5 Ferroxcube for power, audio/video and accelerators**
- C6 Electric motors and accessories**  
Permanent magnet synchronous motors, stepping motors, direct current motors
- CM7a Assemblies (will not be reprinted)**  
Circuit blocks 40-series and CSA70(L), counter modules 50-series, input/output devices
- C8 Variable mains transformers**
- C9 Piezoelectric quartz devices**  
Quartz crystal units, temperature compensated crystal oscillators, compact integrated oscillators, quartz crystal cuts for temperature measurements
- C10 Connectors**
- C11 Non-linear resistors**  
Voltage dependent resistors (VDR), light dependent resistors (LDR), negative temperature coefficient thermistors (NTC), positive temperature coefficient thermistors (PTC)
- C12 Variable resistors and test switches**
- C13 Fixed resistors**
- C14 Electrolytic and solid capacitors**
- C15 Film capacitors, ceramic capacitors, variable capacitors**
- C16 Piezoelectric ceramics, permanent magnet materials**

## RESISTOR PROGRAMME

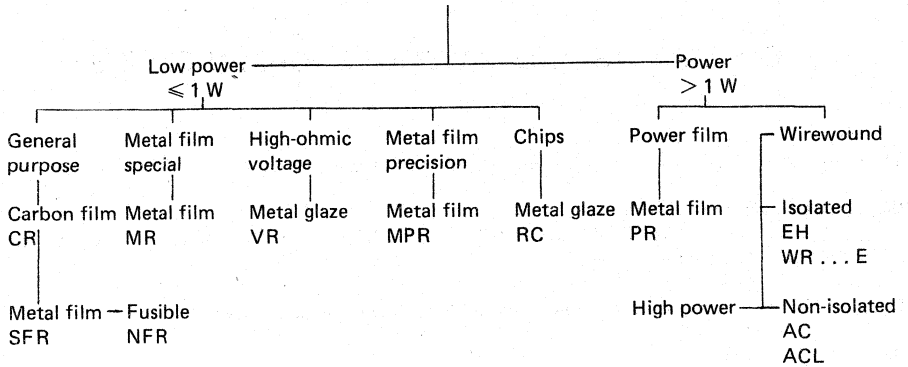

For easy reference, type numbers (such as MR16) are at the top of each page. Orders should, however, always state the 12-figure catalogue number.

The resistor programme is divided into two parts: low power resistors ( $\leq 1 \text{ W}$ ) and power resistors ( $> 1 \text{ W}$ ). The index of catalogue numbers is at the back of this book and lists the relevant page numbers.

All dimensions on drawings are in mm unless otherwise indicated. According to the S.I. units the symbol K (Kelvin) is used instead of  $^{\circ}\text{C}$  in combinations such as K/W. Also  $\Delta T$  is in K. Atmospheric pressure is given in kPa instead of millibars, mm Hg, etc.  $1000 \text{ mbar} = 100 \text{ kPa}$ .

Some devices are labelled "**Maintenance Type**". The relevant resistors are available for equipment maintenance only and are no longer recommended for equipment production.

GENERAL A





## INTRODUCTION

The data are presented - whenever possible - according to a "format", in which the following items are stated:

## Title

QUICK REFERENCE DATA

APPLICATION

DESCRIPTION

MECHANICAL DATA

Mass

Mounting

Marking

ELECTRICAL DATA

COMPOSITION OF THE TYPE NUMBER

TESTS AND REQUIREMENTS

STANDARD PACKAGING

## DESCRIPTION

Almost all types have a cylindrical ceramic body, either rod or tube. The resistive element is either a carbon film, a metal film or a wound wire element. The film types have been trimmed to the required ohmic resistance by cutting a helical groove in the resistive layer. This process is completely computer controlled and yields a high reliability. The terminations are usually iron end caps to which tinned connecting wires of electrolytic copper are welded. Some of the high power wirewound resistors are provided with solder tags or bolts.

All resistor bodies are coated with a coloured lacquer or enamel for protection. Dependent on the types this lacquer provides electrical, mechanical and/or climatic protection — also against soldering flux and cleaning solvents.

## MECHANICAL DATA

A dimensional sketch and, if applicable, a table of dimensions are given. The lead length of axial types is usually not stated if the resistors are only available on tape.

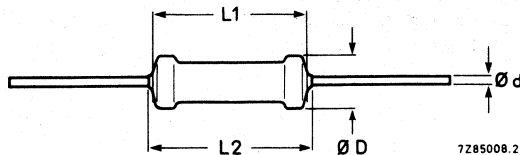

Fig. 1.

The sketch does include, however, length (L), and diameter of the body (D) and the lead diameter (d). For certain types, the length is stated as L1 and L2; L1 is the body length, L2 is the body length plus lacquer on the leads. In other cases the maximum area on the leads which may be covered by lacquer is stated (a1 and a2; usually  $a1 + a2 \leq 1$  mm). By specifying L1/L2 or L and a1/a2 the dimensional "clean lead to clean lead" properties can be determined.

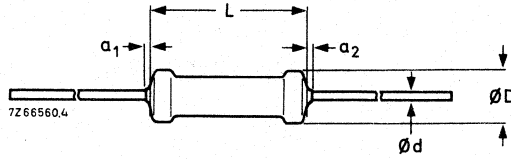

Fig. 2.

For so called "bare bottom" types no lacquer is allowed on the leads at all. The length of the cylindrical body (L or L1) is measured by inserting the leads into the holes of two identical gauge plates and moving these plates parallel to each other until the resistor body is clamped without deformation (IEC publication 294).

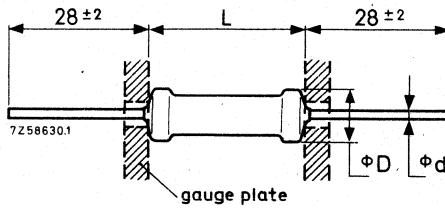

Fig. 3.

The relationship between the diameter of the leads and the diameter of the holes in gauge plate is as follows:

d	hole diameter
0,5	0,8
0,6	1,0
0,7	1,0
0,8	1,2

This method, of course, does not apply to rectangular resistors, "stand-up" types and wirewound resistors with side terminations.

Some resistors (CR25A, SFR25A, VR25A) are available as "stand-up" types. The bent lead is partially covered with insulating lacquer with a breakdown voltage of at least 50 V (d.c.)

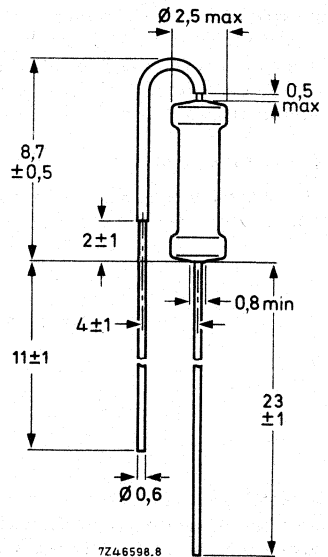

Fig. 4.

**Mass**

The mass (weight) is given per 100 resistors.

**Mounting**

Most types with straight axial leads, as well as most resistors in the "stand-up" version (radial leads), are suitable for processing on automatic insertion equipment and cutting and bending machines. Chip resistors are suitable for handling by automatic chip placement systems.

**Marking**

The resistors are either colour coded or provided with an identification stamp. The colour code consists of a number of coloured bands according to IEC publication 62: "Colour code for fixed resistors". See also IEC 115-1 clause 4.5. The coloured bands indicate the *nominal resistance*, the *tolerance* on the resistance and, if applicable, the *temperature coefficient*. A maximum of bands may be used, but in some instances there are fewer, e.g. if the products are too small. The *resistance code* consists of either 3 or 4 bands and is followed by a distinctly wider band representing the *tolerance*. The temperature coefficient is to the right of the tolerance band and usually positioned on the cap (MR types), as a wide band.

The *resistance code* includes the first two or three *significant figures* of the resistance value (in ohms), followed by a *multiplier*. This is a factor by which the significant-figure value must be multiplied to find the relevant resistance value. Whether two or three significant figures are represented depends on the tolerance:  $\pm 2\%$  and higher requires two bands;  $\pm 1\%$  and lower requires three bands.

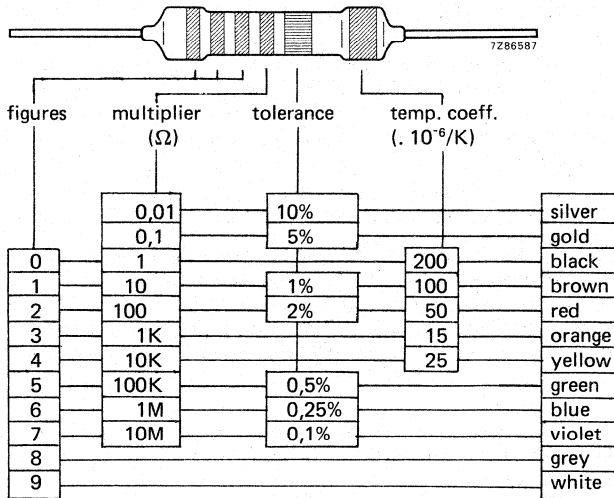

Fig. 5.

The "figures" refer to the first two or three digits of the resistance value of the standard series of values in a decade, according to IEC publication 63 and as indicated in the relevant data sheet and printed at the back of this book.

**Body colours** The resistor bodies are lacquered in different colours to simplify identification:

tan	CR16, CR25, CR37, CR52, CR68
light green	SFR16, SFR25, SFR30
grey	NFR25, NFR30
green	MR16, MR25, MR30, MR52
	MR24E/C/D, MR34E/C/D, MR54E/C/D, MR74E/C/D
	MPR24, MPR34
	AC04, AC05, AC07, AC10, AC15, AC20
	ACL01, ACL02, ACL03
light blue	VR25, VR37, VR68
red	PR37, PR52
brown	WR0167E, WR0842E, WR0825E, WR0865E

Certain resistors are not coded by colour bands but by a stamp giving pertinent data (alphanumeric marking). This is adopted with MIL types MR24E/C/D, MR34E/C/D, MR54E/C/D, MR74E/C/D as well as PR37 and PR52. Resistors outside the standard IEC 63 series of types MPR24 and MPR34 are stamped. All wirewound resistors are likewise stamped. Chip resistors are unmarked but the relevant marking is given on the package.

## ELECTRICAL DATA

The electrical data include: nominal resistance range and tolerance, limiting voltage, temperature coefficient, absolute maximum dissipation, climatic category and stability.

The *limiting voltage* (r.m.s.) for resistor element and insulation is the maximum voltage that may be applied continuously to the resistor element or the insulation, see IEC publications 115-1 and 115-2. Where applicable, *derating details* and performance *nomograms* are given, showing the relationship between power dissipation, ambient temperature, hot-spot temperature and maximum resistance drift after prolonged operation. For power resistors graphs indicate the relationship between temperature rise and dissipation with lead-length or heatsinks as parameters.

The temperature rise in a resistor due to power dissipation is determined by laws of heat conduction, convection and radiation. The maximum body temperature usually occurs in the middle of the resistor and is called the *hot-spot* temperature.

Heat conducted by the leads — which can be considerable in power types — must not reach the melting point of the solder at the joints. This may call for the use of heatsinks and/or longer leads.

In the normal operating temperature range of film resistors the temperature rise at the hot-spot,  $\Delta T$ , is proportional to the power dissipated:  $\Delta T = A \times P$ . The proportionally constant  $A$  gives the temperature rise per watt of dissipated power and can be interpreted as a thermal resistance in K/W. This thermal resistance is a function of the dimensions of the resistor, the heat conductivity of the materials used and, to a lesser degree, of the way of mounting. The sum of the temperature rise and the ambient temperature is:

$$T_m = T_{amb} + \Delta T.$$

The stability of a film resistor during endurance tests is mainly determined by the hot-spot temperature and the resistance. The lower the resistance — other conditions kept constant — the higher the stability due to the greater film thickness.

Summarizing:

dimensions determine		heat resistance
heat resistance x dissipation	=	temperature rise
temperature rise + ambient temperature	=	hot-spot temperature
hot-spot temperature and resistance value determine		stability



**Performance**

When specifying the performance of a resistor, the dissipation is given as a function of the hot-spot temperature, with the ambient temperature as a parameter.

From  $\Delta T = A \times P$  and  $T_m = T_{amb} + \Delta T$  it follows that:

$$P = \frac{T_m - T_{amb}}{A}$$

If P is plotted against  $T_m$  for a constant value of A, parallel straight lines are obtained for different values of the ambient temperature. The slope of these lines,

$\frac{dP}{dT_m} = \frac{1}{A}$ , is the reciprocal of the heat resistance and is characteristic for the resistor.

The stability  $\frac{\Delta R}{R}$  can be determined experimentally, for instance after 1000 h, as a function of the hot-spot temperature with the resistance value as a parameter. It has been found that the resistance changes exponentially with temperature, giving a straight line when  $\log \frac{\Delta R}{R}$  is plotted against  $T_m$ .

A combination of the graphs of P and  $\frac{\Delta R}{R}$  against  $T_m$  gives a nomogram from which the values of several variables can be determined for a resistor of a given size under different working conditions. An example of such a nomogram with fictitious values is given in Fig. 6. The intersection of the broken line with the horizontal axis gives the hot-spot temperature under chosen conditions.

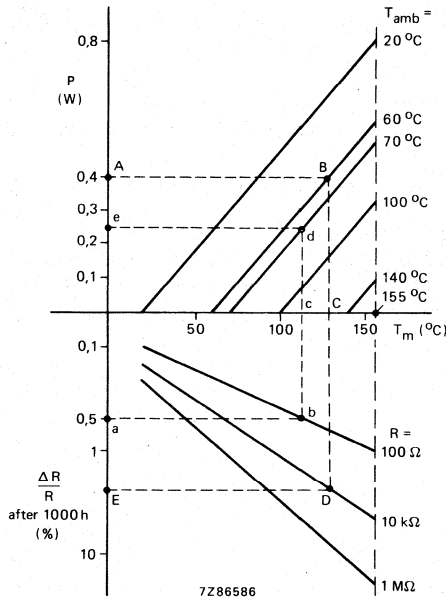

Fig. 6 Performance nomogram (for a fictitious resistor) illustrating the way of specifying the performance of film resistors.

**Example 1**

Assume that a 10 kΩ resistor whose characteristics are described by the nomogram is to be operated at a power dissipation of 0,4 W and an ambient temperature of 60 °C. To find out whether this dissipation is allowable at this ambient temperature and, if so, what the expected stability of the resistor will be, draw in the upper half of the nomogram a horizontal line through A (power dissipation of 0,4 W). This line intersects the 60 °C ambient temperature line at point B, corresponding to a hot-spot temperature of 128 °C (point C). This is safely below the maximum indicated by the broken line at 155 °C; therefore a dissipation of 0,4 W at an ambient temperature of 60 °C is well within the allowable limit.

Extend line BC into the lower half of the nomogram until it intersects the 10 kΩ line at point D. This means that at a hot-spot temperature of 128 °C a resistance change of about 2,5% (point E) can be expected after 1000 hours of operation.

**Example 2**

Assume that a 100 Ω resistor, whose characteristics are described by the nomogram, is to be operated at an ambient temperature of 70 °C with a required stability after 1000 h of 0,5%. It is desired to find the maximum permissible power dissipation. In the lower half of the nomogram, a line that corresponds to a stability of 0,5% intersects the 100 Ω resistance line at point b, corresponding to a hot-spot temperature of 112 °C (point c).

Extending the line b-c into the upper half of the nomogram, it intersects the line indicating an ambient temperature of 70 °C at point d, corresponding to a maximum permissible power dissipation of 0,25 W (point e).

If the power to be dissipated exceeds the value found, a bigger type of resistor should be used.

**The temperature coefficient**

The temperature coefficient of resistance is a ratio which indicates the rate of increase (decrease) of resistance per °C increase (decrease) of temperature within a specified range, and is expressed in parts per million per °C ( $\cdot 10^{-6}/K$ ).

Example: If the temperature coefficient of a resistor of  $R_{nom} = 1 \text{ M}\Omega$  between  $-55 \text{ }^\circ\text{C}$  and  $+155 \text{ }^\circ\text{C}$  is  $\pm 100 \cdot 10^{-6}/K$  its resistance will be:

- at 25 °C:  $1\ 000\ 000 \ \Omega$  (nominal = rated value)
- at +155 °C:  $1\ 000\ 000 \ \Omega + (130 \cdot 100 \cdot 10^{-6}) \times 1\ 000\ 000 \ \Omega = 1\ 013\ 000 \ \Omega$
- at -55 °C:  $1\ 000\ 000 \ \Omega - (80 \cdot 100 \cdot 10^{-6}) \times 1\ 000\ 000 \ \Omega = 992\ 000 \ \Omega$

If the temperature coefficient is specified as  $\leq 100 \cdot 10^{-6}/K$  the resistance will be within the shaded area.

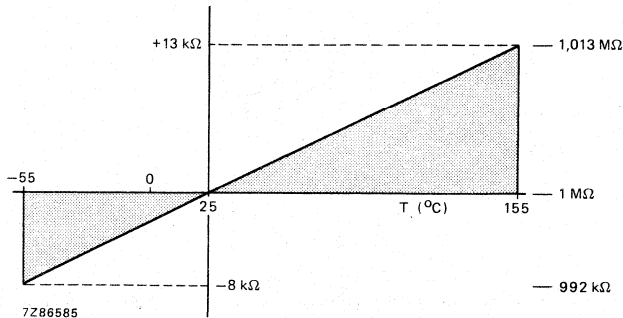

Fig. 7.

### COMPOSITION OF THE CATALOGUE NUMBER

Resistors are ordered by their *catalogue number*, a 12-digit number. The packaging method is an integral part of this number, and so is the resistance code.

### TESTS AND REQUIREMENTS

Essentially all tests on resistors are carried out according to the schedule of IEC publication 115-1 in the specified climatic category and along the lines of IEC publication 68, "Recommended basic climatic and mechanical robustness testing procedure for electronic components". In some instances deviations from the IEC recommendation are made.

### STANDARD PACKAGING

Most types can be processed automatically. They are supplied on tape for this purpose, i.e. a bandolier which fits most commonly used automatic mounting machine. Not all bandolier configurations are identical, the deviating parameters are given in Figs 8 and 9.

#### Axial leads

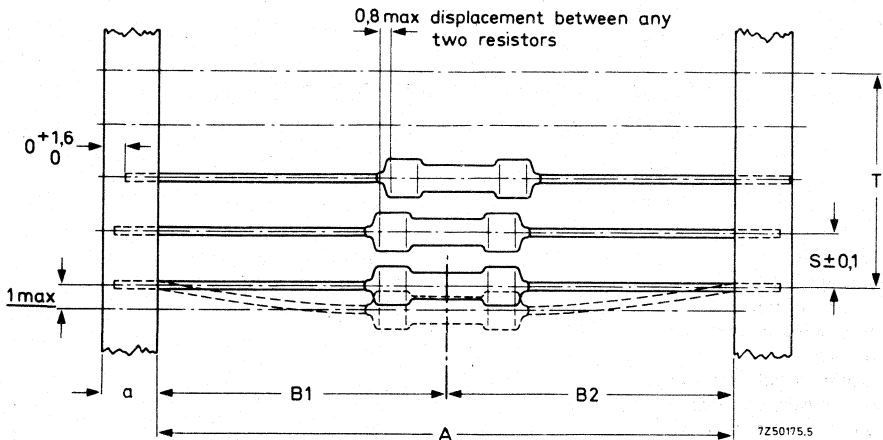

Fig. 8.

S = spacing

T = maximum deviation of spacing: 1 mm per 10 spacings or  
0,5 mm per 5 spacings

a = tape width

A = tape distance

B1 – B2 = centricity

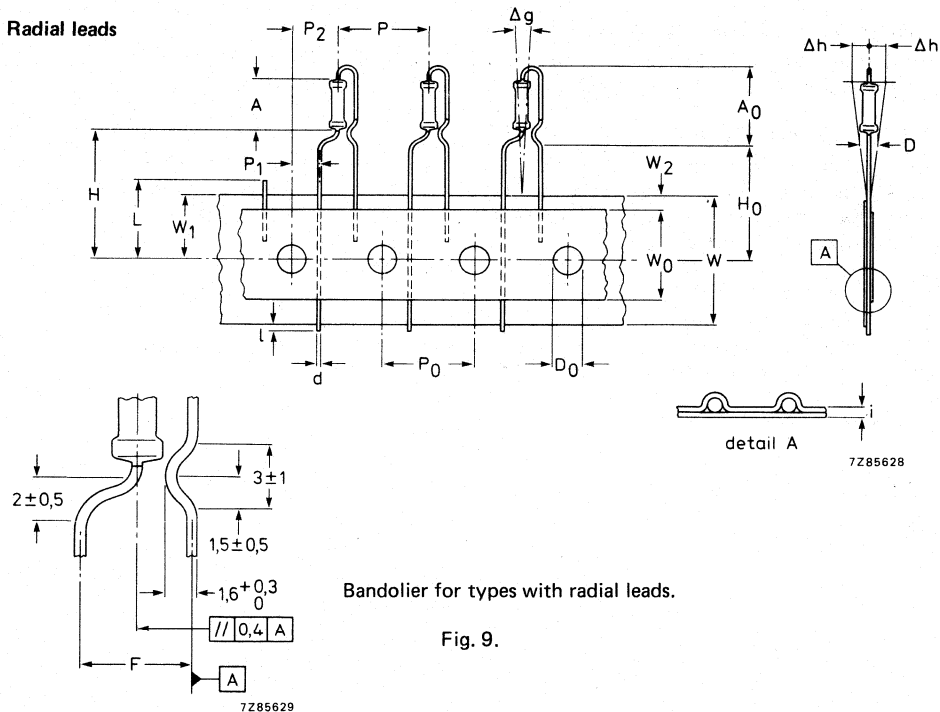

Bandolier for types with radial leads.

Fig. 9.

- |                                   |                |
|-----------------------------------|----------------|
| Body diameter                     | D              |
| Body length                       | A              |
| Mounting height                   | A <sub>0</sub> |
| Lead wire diameter                | d              |
| Pitch of components               | P              |
| Feed hole pitch                   | P <sub>0</sub> |
| Maximum deviation of spacing      | T              |
| Feed hole centre to lead          | P <sub>1</sub> |
| Feed hole centre to body          | P <sub>2</sub> |
| Lead to lead distance             | F              |
| Component alignment               | Δh             |
| Component alignment               | Δg             |
| Tape width                        | W              |
| Hold down tape width              | W <sub>0</sub> |
| Hole position                     | W <sub>1</sub> |
| Hold down tape position           | W <sub>2</sub> |
| Distance component to tape centre | H              |
| Lead wire clinch height           | H <sub>0</sub> |
| Lead wire protrusion              | l              |
| Feed hole diameter                | D <sub>0</sub> |
| Total tape thickness              | i              |
| Length of snipped lead            | L              |

Extraction force for components in the tape plane, vertically to the direction of unreeling:  $\geq 5N$ .

Bandoliers can be reeled; dimensions A and B differ per type.

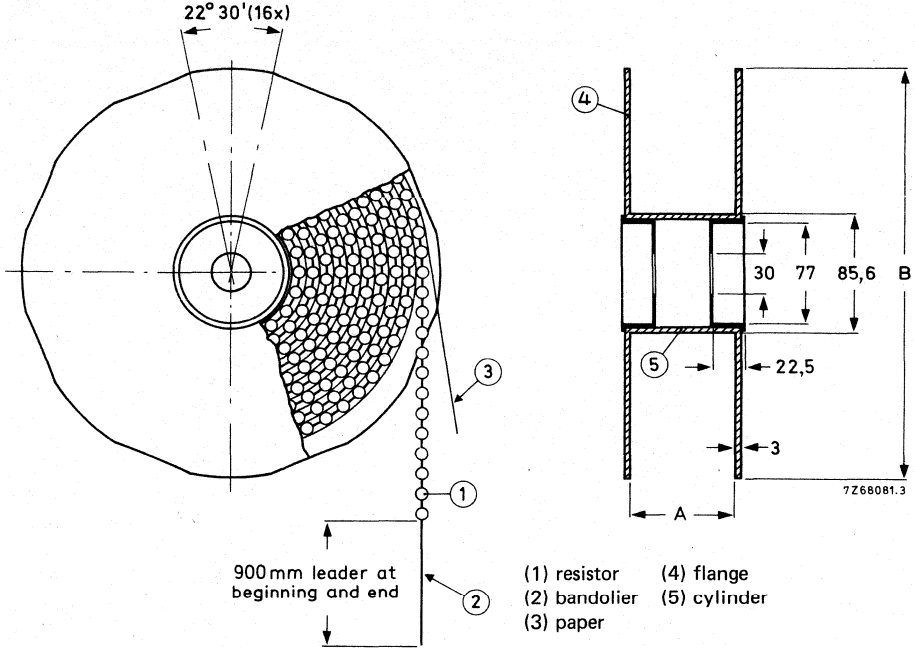

Fig. 10.

Bandoliers may also be supplied concertinaed in a cardboard box ("ammopack").

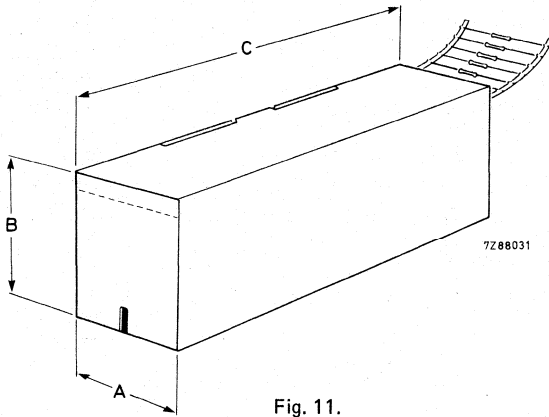

Fig. 11.

"Ammopack" is an abbreviation of "ammunition packing". The dimensions A-B-C vary per type and quantity.

## SURVEY

resistor type	resistance range	tolerance %	dissipation at		type number or basic catalogue number	page			
			°C	W					
Carbon film	1 Ω to 1 MΩ	5; 10	70	0,2	CR16	B3			
				0,33	CR25	B3			
				0,5	CR37	B3			
				0,67	CR52	B3			
				1,15	CR68	B3			
Standard film	10 Ω to 1 MΩ	5	70	0,20	SFR16	B15			
	1 Ω to 10 MΩ	5; 2	70	0,33	SFR25	B21			
	1 Ω to 10 MΩ	5; 2	70	0,50	SFR30	B29			
Fusible	1 Ω to 15 kΩ	5	70	0,33	NFR25	B35			
				0,50	NFR30	B35			
Metal film	10 Ω to 100 kΩ	2; 1	70	0,25	MR16	B43			
	1 Ω to 1 MΩ	0,5; 1; 2	70	0,4	MR25	B43			
				0,5	MR30	B43			
				1	MR52	B43			
MIL film	10 Ω to 1 MΩ	0,1; 0,25; 0,5 and 1	70	0,125	MR24D	B51			
				0,25	MR34D	B51			
				0,5	MR54D	B51			
				0,75	MR74D	B51			
				125	MR24E/C	B51			
			0,125	MR34E/C	B51				
			0,25	MR54E/C	B51				
			0,5	MR74E/C	B51				
			Metal film, precision	24 Ω to 100 kΩ	0,05; 0,02; 0,01	70	0,125	MPR24	B55
				4,99 Ω to 1 MΩ	0,5; 0,25; 0,1	70	0,250	MPR34	B55
0,250	MPR24	B55							
0,40	MPR34	B55							
High voltage	220 Ω to 22 MΩ	1; 5; 10	70	0,25	VR25	B65			
	220 Ω to 33 MΩ	1; 5	70	0,5	VR37	B75			
	100 Ω to 68 MΩ	1; 5	70	1,0	VR68	B75			
Power metal film	2,2 Ω to 51 Ω	5	70	1,6	PR37	B81			
				2,5	PR52	B81			

resistor type	resistance range	tolerance %	dissipation at		type number or basic catalogue number	page
			°C	W		
Cemented wirewound	0,1 $\Omega$ to 33 k $\Omega$	5; 10	40	4	AC04	B87
				5	AC05	B87
				7	AC07	B87
				10	AC10	B87
				15	AC15	B87
				20	AC20	B87
Cemented wirewound	0,1 $\Omega$ to 12 k $\Omega$	5; 10	70	1	ACL01	B97
				2	ACL02	B97
				3	ACL03	B97
Enamelled wirewound	4,7 $\Omega$ to 100 k $\Omega$	5	70	4	WR0617E	B105
				7	WR0825E	B105
				11	WR0842E	B105
				17	WR0865E	B105
Rectangular wirewound	0,15 $\Omega$ to 22 k $\Omega$	5; 10	70	4	EH04	B111
				5	EH05	B111
				7	EH07	B111
				9	EH09	B111
				17	EH17	B111
Wirewound with side terminations	1 $\Omega$ to 120 k $\Omega$	5; 10	40	8 to 100	2322 321	B117
				8 to 250	2322 323	B117
Adjustable wirewound	1,2 $\Omega$ to 47 k $\Omega$	5; 10	40	10 to 100	2322 322	B121
				10 to 250	2322 324	B121
Chip	1 $\Omega$ to 10 M $\Omega$	5; 10; 20	70	0,125	RC01	B125

See also index of catalogue numbers at the back of the book.





FIXED RESISTORS

B





## CARBON FILM RESISTORS

### QUICK REFERENCE DATA

Resistance ranges	1 $\Omega$ to 1 M $\Omega$ ; E12 or E24 series		
Resistance tolerance	$\pm 5$ and $\pm 10\%$		
Absolute maximum dissipation at $T_{amb} = 70\text{ }^{\circ}\text{C}^*$	CR16 = 0,2 W; CR25 = 0,33 W; CR37 = 0,5 W; CR52 = 0,67 W; CR68 = 1,15 W		
Basic specification	IEC 115-1 and 115-2		
Climatic category	55/155/56		
Stability after load	see nomogram (Fig. 3)		
climatic tests	$R \leq 220\text{ k}\Omega$	$\Delta R/R$	max. 1,5%
	$R > 220\text{ k}\Omega$	$\Delta R/R$	max. 3%
soldering		$\Delta R/R$	max. 0,5% or 0,5 $\Omega$
short time overload		$\Delta R/R$	max. 1%

### DESCRIPTION

A homogeneous film of pure carbon is deposited on a high grade ceramic body. Resistors  $R < 10\text{ }\Omega$  have an electroless-deposited nickel film. After a helical groove has been cut in the resistive layer, tinned connecting wires of electrolytic copper are welded to the end-caps. The resistors are coated with a tan lacquer which provides electrical, mechanical and climatological protection. The encapsulation is resistant to all cleaning solvents commonly used for printed-wiring boards.

### MECHANICAL DATA

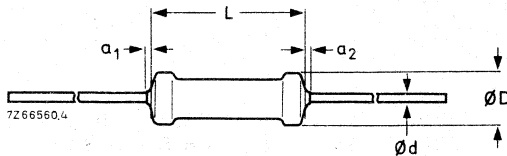

Fig. 1.

type	$D_{max}$	$L_{max}$	d	$a_1 + a_2$
CR16	1,6	4,0	0,5	$\leq 1$
CR25	2,5	6,5	0,6	$\leq 1$
CR37	3,7	10	0,7	$\leq 1$
CR52	5,2	16,5	0,8	$\leq 2$
CR68	6,8	18	0,8	$\leq 2$

\* Dissipation at  $T_{amb} = 70\text{ }^{\circ}\text{C}$  which causes the maximum permissible hot-spot temperature of  $155\text{ }^{\circ}\text{C}$  to occur, irrespective of the resistance drift provoked by this condition.

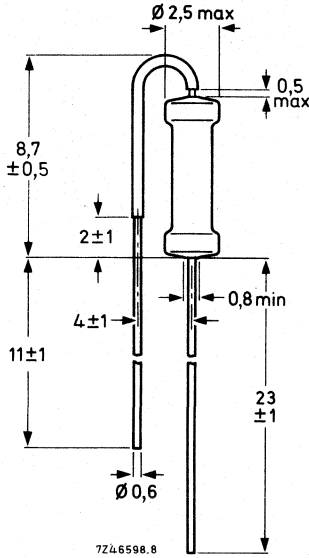

Fig. 2 "Stand-up" type, CR25A, for vertical mounting.

The bent lead is partially covered with an insulating lacquer with a break-down voltage of at least 50 V (d.c.)

The length of the body is measured by inserting the leads into holes of two identical gauge plates and moving these plates parallel to each other until the resistor body is clamped without deformation (see IEC publication 294).

nominal lead diameter (mm)	dia. of hole in gauge plate (mm)
0,5	0,8
0,6/0,7	1,0
0,8	1,2

Mass (per 100 resistors)

CR16	8 g	CR52	96 g
CR25	23 g	CR68	148 g
CR37	42 g		

### Mounting

The resistors are suitable for processing on automatic inserting equipment and cutting and bending machines. Type CR25A can be inserted at a pitch of 1 e.

### Marking

The nominal resistance and the tolerance are marked on the resistors by means of four coloured bands according to IEC publication 62: "Colour code for fixed resistors". See General Section. The code on type CR25A should be read downwards from the bent lead.

**ELECTRICAL DATA****Standard values of rated resistance and tolerance**

Standard values of rated resistance (nominal resistance) are taken from the E12 - E24 series within the range  $1 \Omega$  to  $1 M\Omega$ . These values are given in the table "Standard series of values in a decade" at the back of the handbook.

The tolerance on the rated voltage is either  $\pm 10$  or  $\pm 5\%$ .

The limiting voltage (r.m.s.) for resistor element and insulation is the maximum voltage that may be applied continuously to the resistor element or the insulation, see IEC publication 115-1 and 115-2.

**ELECTRICAL DATA**

type	limiting voltage V r.m.s.	resistance range	tolerance %	series	catalogue number
CR16	150	$10 \Omega$ - $220 k\Omega$ $270 k\Omega$ - $1 M\Omega$	5 10	E24	2322 210 13...
CR16 on reel		$10 \Omega$ - $220 k\Omega$ $270 k\Omega$ - $1 M\Omega$	5 10	E24	2322 210 23... 2322 210 22...
CR25 CR25 on reel on 26 mm bandolier	250	$1 \Omega$ - $1 M\Omega$ $1 \Omega$ - $1 M\Omega$ $1 \Omega$ - $1 M\Omega$	5 5 5	E24	2322 211 13... 2322 211 23... 2322 211 43...
CR25A	250	$1 \Omega$ - $1 M\Omega$	5	E24	2322 106 33...
CR37 CR37 on reel	350	$1 \Omega$ - $1 M\Omega$ $1 \Omega$ - $1 M\Omega$	5 5	E24	2322 212 13... 2322 212 23...
CR52*	500	$1 \Omega$ - $1 M\Omega$	5	E24	2322 213 13...
CR68*	750	$1 \Omega$ - $1 M\Omega$	5	E24	2322 214 13...

**Composition of the catalogue number**

In the above-mentioned catalogue number, replace the first two dots by the first two digits of the resistance value. Replace the third dot by a figure according to the following table:

1 - $9,1 \Omega$	8	10 - $91 k\Omega$	3
10 - $91 \Omega$	9	100 - $910 k\Omega$	4
100 - $910 \Omega$	1	$1 M\Omega$	5
1 - $9,1 k\Omega$	2		

\* For resistance values higher than  $1 M\Omega$ , those from the VR37/VR68 series are recommended, see Fig. 4 of the relevant specification.

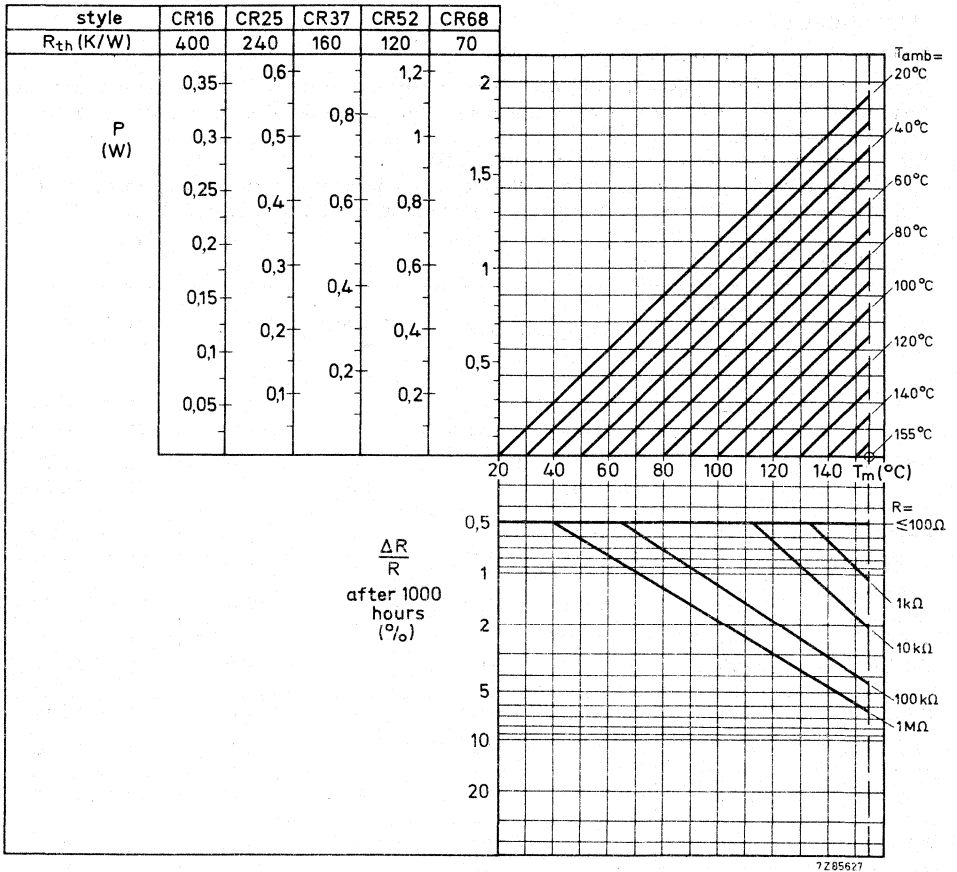

Fig. 3.

Performance nomogram for different styles of resistor showing the relationship between power dissipation  $P$ , ambient temperature  $T_{amb}$ , hot-spot temperature  $T_m$ , resistance value  $R$ , and maximum resistance drift  $\Delta R/R$  after 1000 h of operation.

For continuous operation longer or shorter than 1000 h,  $t_x$ , the stability can be approximated by multiplying the drift  $\Delta R/R$  after 1000 h with the square root of the time ratio, so:

$$(\Delta R/R \text{ after } x \text{ h}) = (\Delta R/R \text{ after } 1000 \text{ h}) \cdot (t_x/1000)^{1/2}$$

See also following notes.

**Notes on nomogram**

1. The nomogram should not be extended beyond the maximum permissible hot-spot temperature of 155 °C.
2. The resistance change given by the nomogram for  $P = 0$  at a particular ambient temperature is indicative of the shelf life stability of a resistor at that temperature.
3. The stability lines do not give exact values for  $\Delta R/R$ , but represent a probability of 95% that the real values will be smaller than those obtained from the nomogram.
4. In the nomogram the limiting voltage of the resistors has not been taken into consideration.
5. IEC publication 115-1 is still based on the conventional method of rating resistors by a fixed "rated dissipation" at 70 °C requiring at that dissipation a fixed maximum permissible drift. In our specification, however, the rated dissipation is no longer specified and also the guaranteed resistance drift is made dependent on the working conditions. To bridge the gap between the system of IEC 115-1 and our system, Fig. 4 is added. In this figure the permissible dissipation at 70 °C for a resistance drift of max. 1,5% after 1000 hours is given, taking into consideration that the hot-spot temperature should not rise above 155 °C (horizontal part of the curves). In our specification the curves of Fig. 4 replace the rated dissipation.

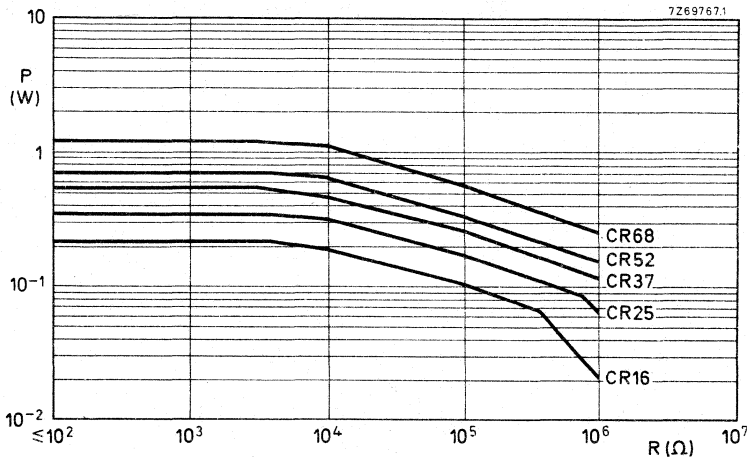

Fig. 4 Maximum permissible dissipation at  $T_{amb} = 70\text{ °C}$  as a function of the resistance value for a resistance drift of 1,5% after 1000 hours or for a maximum temperature of 155 °C without reaching the resistance drift of 1,5%, limiting voltage being taken into account.

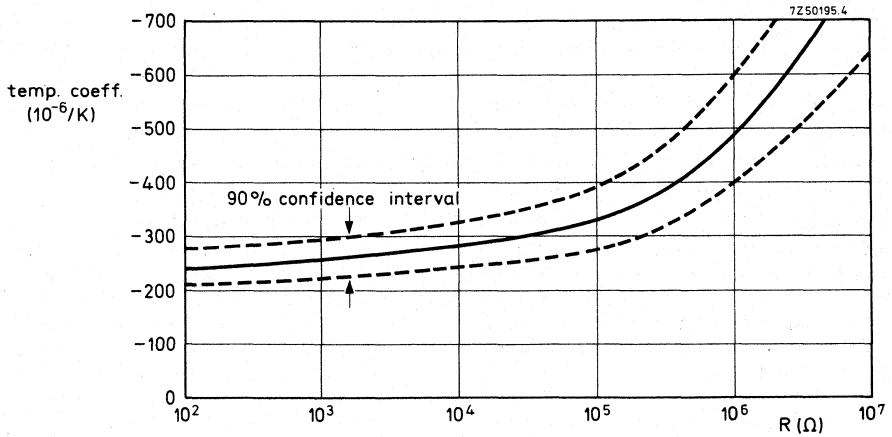

Fig. 5 Temperature coefficient as a function of the resistance value, applicable to all CR types. For values  $< 10 \Omega$  the temperature coefficient is  $\leq + 200 \cdot 10^{-6}/K$ .

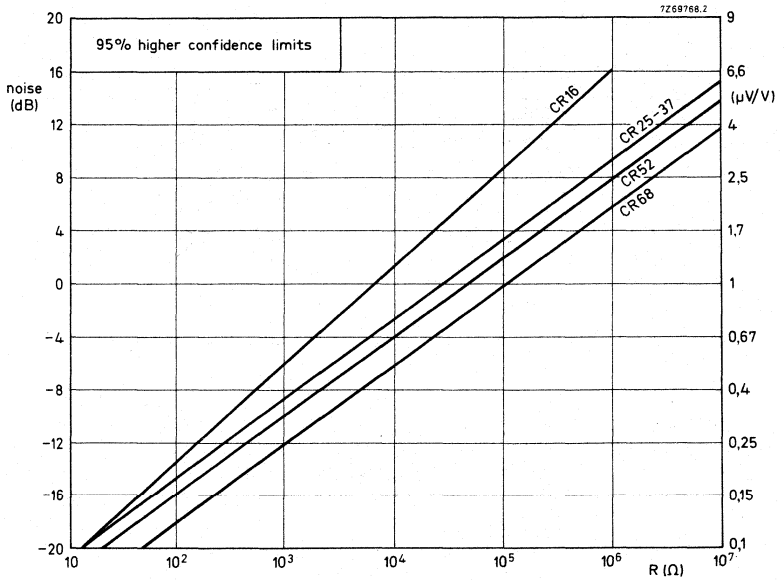

Fig. 6 Noise as a function of the resistance value.  $0 \text{ dB} = 1 \mu V/V$ .



## High-frequency behaviour

The behaviour of a resistor at high frequencies is influenced not only by its construction but also by external factors such as length of leads, environmental stray capacitances and the measuring apparatus. Thus these factors have to be considered when measuring. The following table gives typical values under test conditions at 250 MHz using the measuring arrangement shown below. An RX-meter type 250 A of Boonton Radio Corporation is used.

Frequency: 250 MHz

$R_{nom} (\Omega)$	CR16		CR25		CR37		CR52		CR68	
	$\frac{ Z }{R_{nom}}$	$\varphi^\circ$	$\frac{ Z }{R_{nom}}$	$\varphi^\circ$	$\frac{ Z }{R_{nom}}$	$\varphi^\circ$	$\frac{ Z }{R_{nom}}$	$\varphi^\circ$	$\frac{ Z }{R_{nom}}$	$\varphi^\circ$
10	3,47	70	2,97	70	2,35	61	2,26	61	2,46	63
22	1,72	52	1,61	51	1,43	45	1,40	46	1,37	43
56	1,11	31	1,07	28	1,02	26	1,08	27	1,07	25
100	1,03	23	1,02	22	1,02	17	1,01	18	1,09	20
220	0,99	10	0,99	9	1	6	0,98	4	1	4
560	0,98	0	0,97	-5	0,94	-16	0,97	-5	0,90	-18
1000	0,96	-9	0,92	-15	0,88	-25	0,86	-24	0,79	-31
2200	0,84	-32	0,82	-35	0,69	-47	0,64	-50	0,49	-59
5600	0,50	-60	0,41	-66	0,35	-69	0,31	-72	0,22	-77

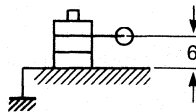
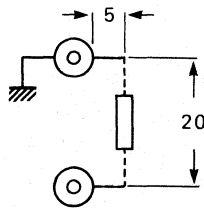

7286516

Fig. 7 Measuring arrangement.

**TESTS AND REQUIREMENTS**

Essentially all tests are carried out according to the schedule of IEC publication 115-1, category 55/155/56 (rated temperature range -55 to + 155 °C; damp heat, long term, 56 days) are carried and along the lines of IEC publication 68, "Recommended basic climatic and mechanical robustness testing procedure for electronic components". In the following table the tests are listed with reference to the relevant clauses of IEC publications 115-1 and 68; a short description is also given of the test procedure and requirements. In some instances deviations from the IEC specification were necessary for our method of specifying.

Table

IEC 115-1 clause	IEC 68 test method	test	procedure	requirements
18	Ua	Robustness of terminations Tensile all samples	$\phi$ 0,5 mm: load 5 N; 10 s $\phi$ 0,6 - 0,7 - 0,8 mm: load 10 N; 10 s	number of failures < $10 \cdot 10^{-6}$
	Ub	Bending half number of samples	$\phi$ 0,5 mm: load 2,5 N; 4 x 90° $\phi$ 0,6 - 0,7 - 0,8 mm: load 5 N; 4 x 90°	
	Uc	Torsion other half number of samples	3 x 360° in opposite directions	no damage  $\Delta R$ max. 0,5% + 0,05 $\Omega$
19	T	Soldering	solderability: 2 s 230 °C, flux 600  thermal shock: 3 s 350 °C, 6 mm from body	good tinning, no damage  $\Delta R$ max. 0,5% + 0,05 $\Omega$
20	Na	Rapid change of temperature	½ h - 55 °C/½ h + 155 °C, 5 cycles	$\Delta R$ max. 0,5% + 0,05 $\Omega$
22	Fc	Vibration	frequency 10-500 Hz, displacement 1,5 mm or acceleration 10g, three directions; total 6 h	no damage  $\Delta R$ max. 0,5% + 0,05 $\Omega$
21	Eb	Bump	3 x 1500 bumps in three directions, 40g	no damage $\Delta R$ max. 0,5% + 0,05 $\Omega$

IEC 115-1 clause	IEC 68 test method	test	procedure	requirements
23		Climatic sequence		
23.2	Ba	Dry heat	16 hours 155 °C	
23.3	D	Damp heat (accel) 1st cycle	24 hours; 55 °C; 95 - 100% R.H.	
23.4	Aa	Cold	2 hours; -55 °C	
23.5	M	Low air pressure	1 hour; 8,5 kPa; 15 - 35 °C	
23.6	D	Damp heat (accel) re- maining cycles	5 days; 55 °C; 95 - 100% R.H.	$R_{ins} = \text{min. } 1000 \text{ M}\Omega$ $\Delta R \text{ max. } 1,5\% \text{ for } R \leq 220 \text{ k}\Omega$ max. 3% for $R > 220 \text{ k}\Omega$
24.2	Ca	Damp heat (steady state)	56 days; 40 °C; 90 - 95% R.H. The dissipation should not exceed 1% of the value indicated by Fig. 4.	$R_{ins}: \text{min. } 1000 \text{ M}\Omega$ $\Delta R \text{ max.: } 1,5\% \text{ for } R \leq 220 \text{ k}\Omega$ 3% for $R > 220 \text{ k}\Omega$
26.2	—	Endurance	1000 hours; 70 °C; dissipation taken from Fig. 4	$\Delta R \text{ max.: } 1,5\%$
11	—	Temperature coefficient	between -55 °C and + 155 °C	see Fig. 5
10	—	Voltage proof on insulation	CR16: 250 V CR25: 500 V CR37: 700 V CR52: 700 V CR68: 1000 V CR93: 1000 V r.m.s. 1 minute	no breakdown
14	—	Noise	IEC publication 195	see Fig. 6
9	—	Insulation resistance	—	min. $10^4 \text{ M}\Omega$
15	—	Short time overload	room temperature, dissipation 6,25 x value taken from Fig. 4, (voltage not more than 2 x limiting voltage), 10 cycles, 5 s on, 45 s off	$\Delta R \text{ max. } 1\%$
13	—	Voltage coefficient	—	$< 5 \cdot 10^{-6}$



STANDARD PACKAGING

type	quantity per box		
	bandolier	bulk	bandolier reeled
CR16	1000	1000	5000
CR25	1000		5000
CR25A			
CR37	1000		5000
CR52	500		
CR68	500		

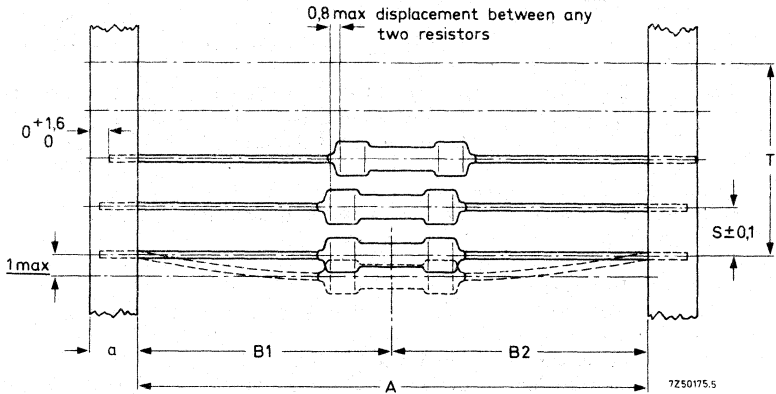

Fig. 8.

type	a ± 0,5	A ± 1,6	B1 - B2 ± max.	S (spacing)	T (max. deviation of spacing)
CR16	6	52,4	1,2	5	1 mm per 10 spacings 0,5 mm per 5 spacings
CR25	6	52,4	1,2	5	
CR37	6	52,4	1,2	5	
CR52	5	66,7	1,2	10	
CR68	5	66,7	1,2	10	

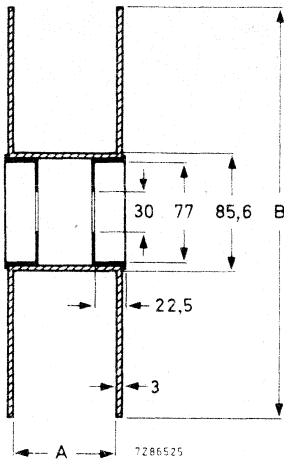

Fig. 9 Reel dimensions.

type	A	B
CR16	75	305
CR25	75	305
CR37	75	305

Leader (without resistors): 900 mm at beginning and end of reeled bandolier.





## STANDARD FILM RESISTORS

metal film

## QUICK REFERENCE DATA

Resistance range	10 $\Omega$ to 1 M $\Omega$ , E24 series		
Resistance tolerance	$\pm 5\%$		
Temperature coefficient			
R $\leq$ 100 k $\Omega$	$\leq 100 \cdot 10^{-6}/K$		
R > 100 k $\Omega$	$\leq 250 \cdot 10^{-6}/K$		
Absolute maximum dissipation at T <sub>amb</sub> = 70 °C *	0,20 W		
Noise			
R $\leq$ 68 k $\Omega$	max.	0,1 $\mu V/V$	
68 k $\Omega$ < R $\leq$ 100 k $\Omega$	max.	0,5 $\mu V/V$	
R > 100 k $\Omega$	max.	1,5 $\mu V/V$	
Basic specifications	IEC 115-1 and 115-2		
Climatic category (IEC 68)	55/155/56		
Stability after	R $\leq$ 100 k $\Omega$		R > 100 k $\Omega$
load	$\Delta R/R$	max. 1% + 0,05 $\Omega$	max. 2% + 0,1 $\Omega$
climatic tests	$\Delta R/R$	max. 1% + 0,05 $\Omega$	max. 2% + 0,1 $\Omega$
soldering	$\Delta R/R$	max. 0,25% + 0,05 $\Omega$	max. 0,25% + 0,05 $\Omega$
short time overload	$\Delta R/R$	max. 0,25% + 0,05 $\Omega$	max. 0,5% + 0,05 $\Omega$

## DESCRIPTION

A homogeneous film of metal alloy is deposited on a high grade ceramic body. After a helical groove has been cut in the resistive layer, tinned connecting wires of electrolytic copper are welded to the end-caps. The resistors are coated with a light-green lacquer which provides electrical, mechanical and climatic protection. The encapsulation is resistant to all cleaning solvents commonly used for printed wiring boards.

## MECHANICAL DATA

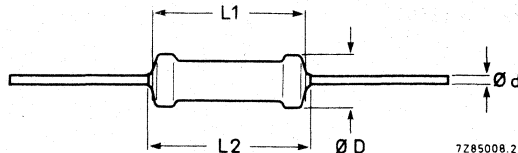

Fig. 1 This standard version is specially made to obtain a minimum "clean lead to clean lead" dimension L2.

D<sub>max</sub> = 1,6 mm; L1 max = 3,7 mm; L2 max = 4,0 mm; d = 0,5 mm.

The length of the body is measured by inserting the leads into holes of two identical gauge plates and moving these plates parallel to each other until the resistor body is clamped without deformation (IEC publication 294). For leads of 0,5 mm diameter, the diameter of the holes in the gauge plates is 0,8 mm.

\* Dissipation at T<sub>amb</sub> = 70 °C which causes the maximum permissible hot-spot temperature of 155 °C to occur, irrespective of the resistance drift provoked by this condition.

**Mass** 8 g per 100 resistors

## Mounting

The resistors are suitable for processing on automatic insertion equipment and cutting and bending machines. The minimum pitch for this type is 3e (7,6 mm).

## Marking

The nominal resistance and the tolerance are marked on the resistors by four coloured bands according to IEC publication 62 "Colour code for fixed resistors". See also General Section.

## ELECTRICAL DATA

### Standard values of rated resistance and tolerance

Standard values of rated resistance (nominal resistance) are taken from the E24 series within the range 10  $\Omega$  to 1 M $\Omega$ . E24 series of values is given in the table "Standard series of values in a decade" at the back of the handbook. The tolerance on the rated resistance is  $\pm 5\%$ .

The limiting voltage (r.m.s.) for resistor element and insulation is the maximum voltage that may be applied continuously to the resistor element or the insulation. See IEC publications 115-1 and 115-2. This voltage is 150 V.

### COMPOSITION OF THE CATALOGUE NUMBER

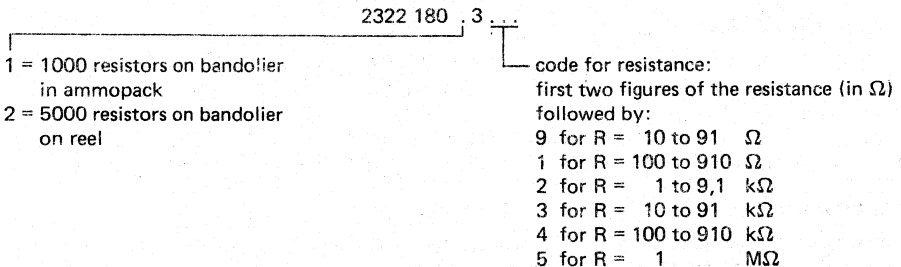

### Example

The catalogue number of a resistor SFR16 of 5600  $\Omega$ , taped on a bandolier of 1000 items, supplied in ammopack, is 2322 180 13562.



## TESTS AND REQUIREMENTS

Essentially all tests are carried out according to the schedule of IEC publication 115-1, category 55/155/56 (rated temperature range  $-55$  to  $+155$  °C; damp heat, long term, 56 days) and along the lines of IEC publication 68, "Recommended basic climatic and mechanical robustness testing procedure for electronic components". In the following table the tests are listed with reference to the relevant clauses of IEC publications 115-1 and 68; a short description is also given of the test procedure and requirements. In some instances deviations from the IEC recommendation were necessary for our method of specifying.

Table 4

IEC 115-1 clause	IEC 68 test method	test	procedure	requirements
18	Ua	Robustness of terminations Tensile all samples	$\phi$ 0,5 mm; load 5N; 10 s	} number of failures: < 10 ppm  no damage $\Delta R$ max. 0,25% + 0,05 $\Omega$
	Ub	Bending half number of samples	$\phi$ 0,5 mm; load 2,5N; 4 x 90°	
	Uc	Torsion other half number of samples	3 x 360° in opposite directions	
19	T	Soldering	solderability: 2 s 230 °C, flux 600 thermal shock: 3 s 350 °C, 6 mm from body	good tinning, no damage $\Delta R$ max. 0,25% + 0,05 $\Omega$
20	Na	Rapid change of temperature	$\frac{1}{2}$ h $-55$ °C/ $\frac{1}{2}$ h $+155$ °C, 5 cycles	$\Delta R$ max. 0,25% + 0,05 $\Omega$
22	Fc	Vibration	frequency 10-500 Hz, displacement 1,5 mm or acceleration 10g, three directions; total 6 h (3 x 2 h)	no damage $\Delta R$ max. 0,25% + 0,05 $\Omega$
21	Eb	Bump	3 x 1500 bumps in three directions, 40g	no damage $\Delta R$ max. 0,25% + 0,05 $\Omega$

IEC 115-1 clause	IEC 68 test method	test	procedure	requirements
23		Climatic sequence		
23.2	Ba	Dry heat	16 h, 155 °C	
23.3	D	Damp heat (accel) 1st cycle	24 h; 55 °C; 95-100% R.H.	
23.4	Aa	Cold	2 h; -55 °C	
23.5	M	Low air pressure	2 h; 8,5 kPa 15-35 °C	
23.6	D	Damp heat (accel) re-maining cycles	5 days; 55 °C; 95-100% R.H.	$R_{ins}$ min. 1000 M $\Omega$ $R \leq 100$ k $\Omega$ : $\Delta R$ max. 1,0% + 0,05 $\Omega$ $R > 100$ k $\Omega$ : $\Delta R$ max. 2% + 0,1 $\Omega$
24.2	Ca	Damp heat steady state	56 days; 40 °C; 90-95% R.H. dissipation 0,01 P <sub>n</sub>	$R_{ins}$ min. 1000 M $\Omega$ $R \leq 100$ k $\Omega$ : $\Delta R$ max. 1,0% + 0,05 $\Omega$ $R > 100$ k $\Omega$ : $\Delta R$ max. 2% + 0,1 $\Omega$
26.2	—	Endurance	1000 hours; 70 °C; nominal dissipation or V <sub>max</sub>	$R \leq 100$ k $\Omega$ : $\Delta R$ max. 1,0% + 0,05 $\Omega$ $R > 100$ k $\Omega$ : $\Delta R$ max. 2% + 0,1 $\Omega$
11	—	Temperature coefficient	between -55 °C and +155 °C	$R \leq 100$ k $\Omega$ : $\leq 100 \cdot 10^{-6}/K$ $R > 100$ k $\Omega$ : $\leq 200 \cdot 10^{-6}/K$
10	—	Voltage proof on insulation	300 V (r.m.s.) 1 minute	no breakdown
14	—	Noise	IEC publication 195	$R \leq 68$ k $\Omega$ : max. 0,1 $\mu V/V$ $68$ k $\Omega < R \leq 100$ k $\Omega$ : max. 0,5 $\mu V/V$ $R > 100$ k $\Omega$ : max. 1,5 $\mu V/V$
9	—	Insulation resistance		min. 10 <sup>4</sup> M $\Omega$
15	—	Short time overload	Room temperature, dissipation 6,25 x 0,125 W (voltage not more than 2 x limiting voltage), 10 cycles 5 s on, 45 s off	$R \leq 100$ k $\Omega$ : $\Delta R$ max. 0,25% + 0,05 $\Omega$ $R > 100$ k $\Omega$ : $\Delta R$ max. 0,5% + 0,05 $\Omega$

**PACKAGING**

The resistors are supplied on bandolier; either 1000 resistors in ammpack or 5000 resistors on reel.

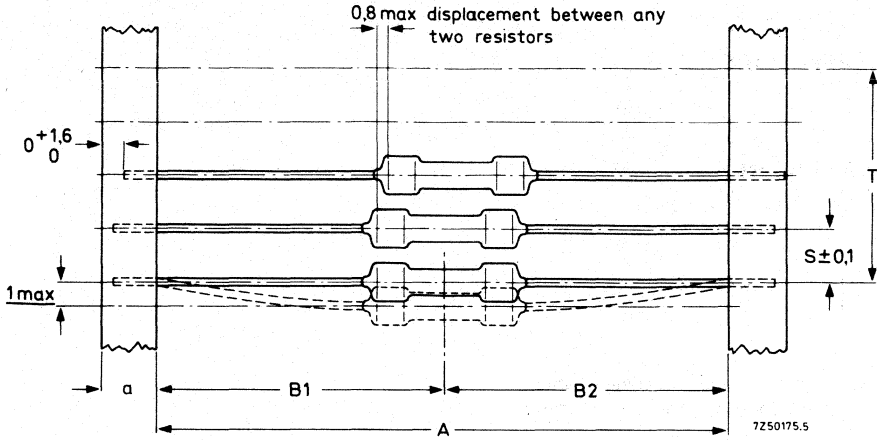
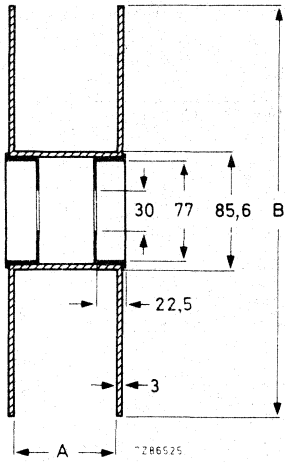

Fig. 2.

type	a $\pm 0,5$	A $\pm 1,5$	B1-B2 $\pm \text{max.}$	S (spacing)	T (max. deviation of spacing)
SFR16	6	52,5	1,2	5	1 mm per 10 spacings, 0,5 mm per 5 spacings

Reel dimensions



type	quantity	A	B
SFR16	5000	75	305

Fig. 3 Length of leader at beginning and end (bandolier without resistors) is 300 mm.

## STANDARD FILM RESISTORS

metal film

### QUICK REFERENCE DATA

Resistance range	1 $\Omega$ to 10 M $\Omega$ , E24 series		
Resistance tolerance	$\pm 5\%$ and $\pm 2\%$		
Temperature coefficient			
$R \leq 1 \text{ M}\Omega$	$\leq 100 \cdot 10^{-6}/\text{K}$		
$R > 1 \text{ M}\Omega$	$\leq 250 \cdot 10^{-6}/\text{K}$		
Absolute maximum dissipation at $T_{\text{amb}} = 70 \text{ }^\circ\text{C}^*$	0,33 W		
Noise			
$R \leq 1 \text{ M}\Omega$	max.	0,1 $\mu\text{V}/\text{V}$	
$R > 1 \text{ M}\Omega$	max.	1,5 $\mu\text{V}/\text{V}$	
Basic specifications	IEC 115-1 and 115-2		
Climatic category (IEC 68)	55/155/56		
Stability after	$R \leq 1 \text{ M}\Omega$		$R > 1 \text{ M}\Omega$
load	$\Delta R/R$	max. 1% + 0,05 $\Omega$	2% + 0,1 $\Omega$
climatic tests	$\Delta R/R$	max. 1% + 0,05 $\Omega$	2% + 0,1 $\Omega$
soldering	$\Delta R/R$	max. 0,25% + 0,05 $\Omega$	0,25% + 0,05 $\Omega$
short time overload	$\Delta R/R$	max. 0,25% + 0,05 $\Omega$	0,25% + 0,05 $\Omega$

### DESCRIPTION

A homogeneous film of metal alloy is deposited on a high grade ceramic body. After a helical groove has been cut in the resistive layer, tinned connecting wires of electrolytic copper are welded to the end-caps. The resistors are coated with a light-green lacquer which provides electrical, mechanical and climatic protection. The encapsulation is resistant to all cleaning solvents commonly used for printed wiring boards.

### MECHANICAL DATA

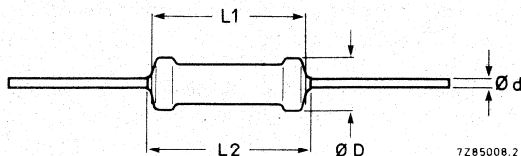

Fig. 1 Standard version, style 1 and 2. Style 2 is specially made to obtain a minimum "clean lead to clean lead" dimension L2 (bare bottom).

type and style	$D_{\text{max}}$	L1 max	L2 max	d
SFR25, style 1	2,5	6,5	7,5	0,6
SFR25, style 2	2,5	6,5	7,0	0,6

\* This is the dissipation at  $T_{\text{amb}} = 70 \text{ }^\circ\text{C}$  which causes the maximum permissible hot-spot temperature of 155  $^\circ\text{C}$  to occur, irrespective of the resistance drift provoked by this condition.

The length of the body is measured by inserting the leads into holes of two identical gauge plates and moving these plates parallel to each other until the resistor body is clamped without deformation (IEC publication 294). For leads of 0,6 mm diameter, the diameter of the holes in the gauge plates is 1,0 mm.

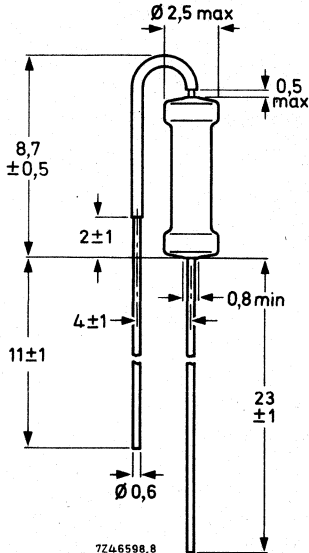

Fig. 2 "Stand-up" type SFR25A, for vertical mounting. The bent lead is partially covered with an insulating lacquer with a breakdown voltage of at least 50 V (d.c.).

**Mass** 25 g per 100 resistors.

### Mounting

Styles 1 and 2 are suitable for processing on automatic insertion equipment and cutting and bending machines. The minimum pitch for style 1 is 5e (12,7 mm) and for style 2, 4e (10,2 mm). The "stand-up" type, SFR25A, can be inserted into holes with a pitch of 1e.

### Marking

The nominal resistance and the tolerance are marked on the resistors by four coloured bands according to IEC publication 62 "Colour code for fixed resistors". See also General Section.

## ELECTRICAL DATA

### Standard values of rated resistance and tolerance

Standard values of rated resistance (nominal resistance) are taken from the E24 series within the range 1  $\Omega$  to 1 M $\Omega$ . E24 series of values is given in the table "Standard series of values in a decade" at the back of the handbook. The tolerance on the rated resistance is either  $\pm 5\%$  or  $\pm 2\%$ .

The limiting voltage (r.m.s.) for resistor element and insulation is the maximum voltage that may be applied continuously to the resistor element or the insulation. See IEC publications 115-1 and 115-2. This voltage is 250 V.

type	style	packing	quantity	resistance range	tolerance ± %	catalogue number
SFR25	1	ammopack	1000	1 Ω to 1 MΩ	5	2322 181 13 ...
			5000			2322 181 73 ...
		on reel	5000			2322 181 23 ...
SFR25 "bare-bottom"	2	ammopack	1000	1 Ω to 10 MΩ	5	2322 181 53 ...
			5000			2322 181 43 ...
		on reel	1000	1 Ω to 1 MΩ	2	2322 181 54 ...
			5000	1 Ω to 10 MΩ	5	2322 181 63 ...
			5000	1 Ω to 1 MΩ	2	2322 181 64 ...
SFR25 CECC approved 40101  	2	ammopack	1000	1 Ω to 1 MΩ	5	2322 183 13 ...
			1000		2	2322 183 14 ...
		on reel	5000		5	2322 183 43 ...
			5000		2	2322 183 44 ...
			5000		5	2322 183 63 ...
			5000		2	2322 183 64 ...
SFR25 26 mm bandolier	2	ammopack	2000	1 Ω to 10 MΩ	5	2322 181 03 ...
SFR25A "stand-up"	2	in box (loose)	1000	1 Ω to 10 MΩ	5	2322 181 33 ...
SFR25AS radial taped	2	in box	2000	1 Ω to 10 MΩ	5	2322 184 33 ...
		on reel	4000			2322 184 43 ...

### COMPOSITION OF THE CATALOGUE NUMBER

The catalogue number in the above table is completed by inserting the resistance code: the first two figures of the resistance (in Ω) followed by:

- 8 for R = 1 to 9,1 Ω
- 9 for R = 10 to 91 Ω
- 1 for R = 100 to 910 Ω
- 2 for R = 1 to 9,1 kΩ
- 3 for R = 10 to 91 kΩ
- 4 for R = 100 to 910 kΩ
- 5 for R = 1 to 9,1 MΩ
- 6 for R = 10 MΩ

### Example

The catalogue number of a resistor SFR25 of 5600 Ω ±5%, bare-bottom version, taped on a bandolier of 1000 items, supplied in ammpack, is 2322 181 53562.

## TESTS AND REQUIREMENTS

Essentially all tests are carried out according to the schedule of IEC publication 115-1, category 55/155/56 (rated temperature range  $-55$  to  $+155$  °C; damp heat, long term, 56 days) and along the lines of IEC publication 68, "Recommended basic climatic and mechanical robustness testing procedure for electronic components". In the following table the tests are listed with reference to the relevant clauses of IEC publications 115-1 and 68; a short description is also given of the test procedure and requirements. In some instances deviations from the IEC recommendation were necessary for our method of specifying.

Table 4

IEC 115-1 clause	IEC 68 test method	test	procedure	requirements
18	Ua	Robustness of terminations Tensile all samples	$\phi$ 0,6 mm; load 10N; 10 s	number of failures < 10 ppm
	Ub	Bending half number of samples	$\phi$ 0,6 mm; load 5N; $4 \times 90^\circ$	
	Uc	Torsion other half number of samples	$3 \times 360^\circ$ in opposite directions	no damage $\Delta R$ max. 0,25% + 0,05 $\Omega$
19	T	Soldering	solderability: 2 s 230 °C, flux 600 thermal shock: 3 s 350 °C, 6 mm from body	good tinning, no damage $\Delta R$ max. 0,25% + 0,05 $\Omega$
20	Na	Rapid change of temperature	$\frac{1}{2}$ h $-55$ °C/ $\frac{1}{2}$ h $+155$ °C, 5 cycles	$R \leq 1$ M $\Omega$ : $\Delta R$ max. 0,25% + 0,05 $\Omega$ $R > 1$ M $\Omega$ : $\Delta R$ max. 0,5% + 0,05 $\Omega$
22	Fc	Vibration	frequency 10-500 Hz, displacement 1,5 mm or acceleration 10g, three directions; total 6 h ( $3 \times 2$ h)	no damage $\Delta R$ max. 0,25% + 0,05 $\Omega$
21	Eb	Bump	$3 \times 1500$ bumps in three directions, 40g	no damage $\Delta R$ max. 0,25% + 0,05 $\Omega$



IEC 115-1 clause	IEC 68 test method	test	procedure	requirements
23		Climatic sequence		
23.2	Ba	Dry heat	16 h, 155 °C	
23.3	D	Damp heat (accel) 1st cycle	24 h; 55 °C; 95-100% R.H.	
23.4	Aa	Cold	2 h; -55 °C	
23.5	M	Low air pressure	2 h; 8,5 kPa; 15-35 °C	
23.6	D	Damp heat (accel) remaining cycles	5 days; 55 °C; 95-100% R.H.	$R_{ins}$ min. 1000 M $\Omega$ $R \leq 1$ M $\Omega$ : $\Delta R$ max. 1% + 0,05 $\Omega$ $R > 1$ M $\Omega$ : $\Delta R$ max. 2% + 0,1 $\Omega$
24.2	Ca	Damp heat steady state	56 days; 40 °C; 90-95% R.H. dissipation 0,01 P <sub>n</sub>	$R_{ins}$ min. 1000 M $\Omega$ $R \leq 1$ M $\Omega$ : $\Delta R$ max. 1% + 0,05 $\Omega$ $R > 1$ M $\Omega$ : $\Delta R$ max. 2% + 0,1 $\Omega$
26.2	—	Endurance	1000 hours; 70 °C; nominal dissipation or V <sub>max</sub>	$R \leq 1$ M $\Omega$ : $\Delta R$ max. 1% + 0,05 $\Omega$ $R > 1$ M $\Omega$ : $\Delta R$ max. 2% + 0,1 $\Omega$
11	—	Temperature coefficient	between -55 °C and + 155 °C	$R \leq 1$ M $\Omega$ : $\leq 100 \cdot 10^{-6}/K$ $R > 1$ M $\Omega$ : $\leq 250 \cdot 10^{-6}/K$
10	—	Voltage proof on insulation	SFR25, style 1 700 V (r.m.s.) SFR25, style 2 500 V (r.m.s.) SFR25A 600 V (r.m.s.) 1 minute	no breakdown
14	—	Noise	IEC publication 195	$R \leq 1$ M $\Omega$ : max. 0,1 $\mu V/V$ $R > 1$ M $\Omega$ : max. 1,5 $\mu V/V$
9	—	Insulation resistance		min. 10 <sup>4</sup> M $\Omega$
—	—	Short time overload	Room temperature, dissipation 6,25 P <sub>n</sub> (voltage not more than 2 x limiting voltage), 10 cycles 5 s on, 45 s off	$\Delta R$ max. 0,25% + 0,05 $\Omega$

**PACKAGING**

Resistors with axial leads are supplied on bandolier in ammpack or on reel; those with radial leads are either loose in a cardboard box or, with bent leads, on a bandolier in ammpack.

type and style	quantity per box		
	on bandolier ammpack	bulk loose	bandolier on reel
SFR25, style 1	1000/5000	—	5000
SFR25, style 2	1000/2000/5000	—	5000
SFR25A	—	1000	—
SFR25AS	2000	—	4000

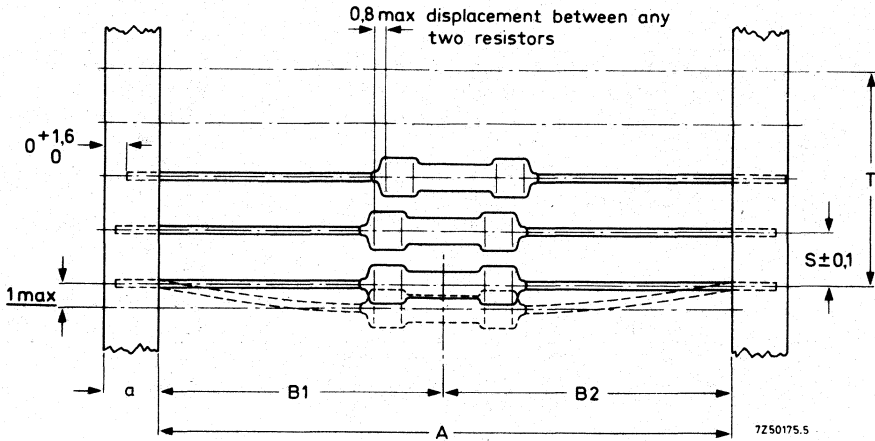

Fig. 3 Bandolier for SFR25, style 1 and 2.

type and style	a ± 0,5	A	B1-B2 ± max.	S (spacing)	T (max. deviation of spacing)
SFR25, style 1	6	52,5 ± 1,5	1,2	5	1 mm per 10 spacings 0,5 mm per 5 spacings
SFR25, style 2	6	26 + 1,5 - 0	1,0	5	
SFR25, style 2	6	52,5 ± 1,5	1,2	5	

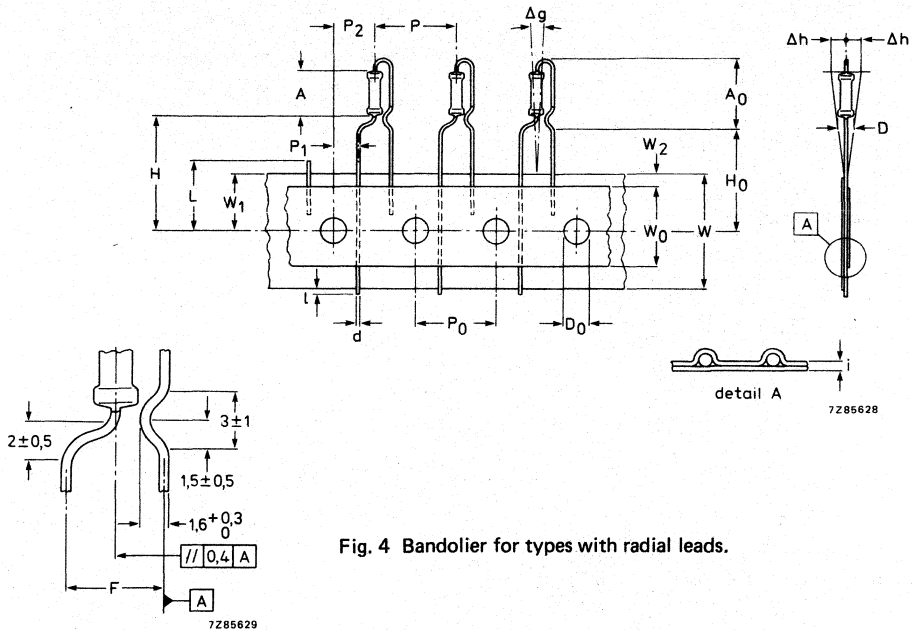

Fig. 4 Bandolier for types with radial leads.

Body diameter	D	max.	2,50
Body length	A	max.	7,00
Mounting height	A <sub>0</sub>	max.	12,50
Lead wire diameter	d		0,60 ± 0,06
Pitch of components	P		12,7 ± 1,0
Feed hole pitch	P <sub>0</sub>		12,7 ± 0,3
Maximum deviation of spacing	T		1,0 per 20 spacings 0,5 per 4 spacings
Feed hole centre to lead	P <sub>1</sub>		3,85 ± 0,5
Feed hole centre to body	P <sub>2</sub>		6,35 ± 0,4
Lead to lead distance	F		5,08 + 0,6 - 0,2
Component alignment	Δh		0 ± 2 mm
Component alignment	Δg		0 ± 3°
Tape width	W		18,0 + 1 - 0,8
Hold down tape width	W <sub>0</sub>	min.	12,5 or 6 mm
Hole position	W <sub>1</sub>		9,0 ± 0,5
Hold down tape position	W <sub>2</sub>		2 + 0 - 1,5
Distance component to tape centre	H		19,0 ± 1
Lead wire clinch height	H <sub>0</sub>		16,5 ± 0,5
Lead wire protrusion	l	max.	0
Feed hole diameter	D <sub>0</sub>		4,0 ± 0,2
Total tape thickness	i	max.	0,7
Length of snapped lead	L	max.	11,0

Extraction force for components in the tape plane, vertically to the direction of unreeling: ≥ 5N.

Reel dimensions

type	quantity	A	B
SFR25	5000	75	305
SFR25AS	4000	40	356

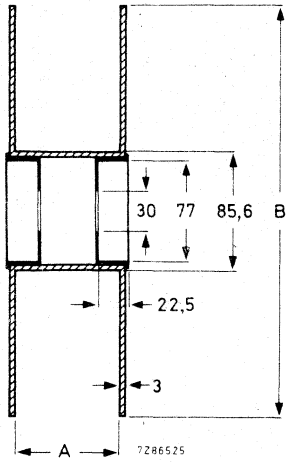

Fig. 5 Length of leader at beginning and end (bandolier without resistors) is 300 mm.



## STANDARD FILM RESISTORS

metal film

### QUICK REFERENCE DATA

Resistance range	1 $\Omega$ to 10 M $\Omega$ , E24 series		
Resistance tolerance	$\pm 5$ and $\pm 2\%$		
Temperature coefficient			
R $\leq$ 1 M $\Omega$	$\leq 100 \cdot 10^{-6}/k$		
R > 1 M $\Omega$	$\leq 250 \cdot 10^{-6}/k$		
Absolute maximum dissipation at T <sub>amb</sub> = 70 °C *	0,50 W		
Noise			
R $\leq$ 1 M $\Omega$	max.	0,1 $\mu V/V$	
R > 1 M $\Omega$	max.	1,5 $\mu V/V$	
Basic specifications	IEC 115-1 and 115-2		
Climatic category (IEC 68)	55/155/56		
Stability after	R $\leq$ 1 M $\Omega$		R > 1 M $\Omega$
load	$\Delta R/R$	max. 1% + 0,05 $\Omega$	2% + 0,1 $\Omega$
climatic tests	$\Delta R/R$	max. 1% + 0,05 $\Omega$	2% + 0,1 $\Omega$
soldering	$\Delta R/R$	max. 0,25% + 0,05 $\Omega$	0,25% + 0,05 $\Omega$
short time overload	$\Delta R/R$	max. 1% + 0,05 $\Omega$	1% + 0,05 $\Omega$

### DÉSCRIPTION

A homogeneous film of metal alloy is deposited on a high grade ceramic body. After a helical groove has been cut in the resistive layer tinned connecting wires of electrolytic copper are welded to the end-caps. The resistors are coated with a light-green lacquer which provides electrical, mechanical and climatic protection. The encapsulation is resistant to all cleaning solvents commonly used for printed wiring boards.

### MECHANICAL DATA

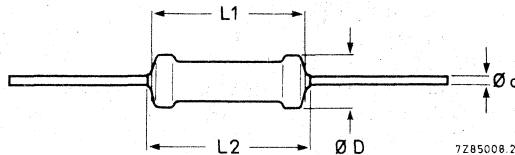

Fig. 1 Dmax = 3,0 mm; L1 max = 8,5 mm; L2 max = 9,5 mm; d = 0,7 mm.

The length of the body is measured by inserting the leads into holes of two identical gauge plates and moving these plates parallel to each other until the resistor is clamped without deformation (IEC publication 294). For leads of 0,7 mm diameter, the diameter of the holes in the gauge plates is 1,0 mm

\* This is the dissipation at T<sub>amb</sub> = 70 °C which causes the maximum permissible hot-spot temperature of 155 °C to occur, irrespective of the resistance drift provoked by this condition.

**Mass** 33 g per 100 resistors

### Mounting

The resistors are suitable for processing on automatic insertion equipment and cutting and bending machines. The minimum pitch for this type is 5e (12,7 mm).

### Marking

The nominal resistance and the tolerance are marked on the resistors by four coloured bands according to IEC publication 62 "Colour code for fixed resistors". See also General Section.

## ELECTRICAL DATA

### Standard values of rated resistance and tolerance

Standard values of rated resistance (nominal resistance) are taken from the E24 series within the range 1  $\Omega$  to 10 M $\Omega$ . E24 series of values is given in the table "Standard series of values in a decade" at the back of the handbook. The tolerance on the rated resistance is either  $\pm 5\%$  or  $\pm 2\%$ .

The limiting voltage (r.m.s.) for resistor element and insulation is the maximum voltage that may be applied continuously to the resistor element or the insulation, see IEC publication 115-1 and 115-2. This voltage is 350 V.

type	packing	quantity	resistance range	tolerance $\pm \%$	catalogue number
SFR30	ammopack	1000	1 $\Omega$ to 10 M $\Omega$	5	2322 182 13 ...
		1000	1 $\Omega$ to 1 M $\Omega$	2	2322 182 14 ...
	on reel	5000	1 $\Omega$ to 10 M $\Omega$	5	2322 182 23 ...
		5000	1 $\Omega$ to 1 M $\Omega$	2	2322 182 24 ...
SFR30 CECC approved 40101 	ammopack	1000	1 $\Omega$ to 1 M $\Omega$	5	2322 185 13 ...

### COMPOSITION OF THE CATALOGUE NUMBER

The catalogue number in the above table is completed by inserting the resistance code: the first two figures of the resistance (in  $\Omega$ ), followed by:

- 8 for R = 1 to 9,1  $\Omega$
- 9 for R = 10 to 91  $\Omega$
- 1 for R = 100 to 910  $\Omega$
- 2 for R = 1 to 9,1 k $\Omega$
- 3 for R = 10 to 91 k $\Omega$
- 4 for R = 100 to 910 k $\Omega$
- 5 for R = 1 to 9,1 M $\Omega$
- 6 for R = 10 to 91 M $\Omega$

### Example

The catalogue number of a resistor SFR30 of 5600  $\Omega \pm 5\%$ , on a bandolier of 1000 items, supplied in ammopack, is 2322 182 13562.

## TESTS AND REQUIREMENTS

Essentially all tests are carried out according to the schedule of IEC publication 115-1, category 55/155/56 (rated temperature range  $-55$  to  $+155$  °C; damp heat, long term, 56 days) and along the lines of IEC publication 68, "Recommended basic climatic and mechanical robustness testing procedure for electronic components". In the following table the tests are listed with reference to the relevant clauses of IEC publications 115-1 and 68; a short description is also given of the test procedure and requirements. In some instances deviations from the IEC recommendation were necessary for our method of specifying.

Table 4

IEC 115-1 clause	IEC 68 test method	test	procedure	requirements
18	Ua	Robustness of terminations Tensile all samples	$\phi$ 0,7 mm; load 10N; 10 s	} number of failures < 10 ppm
	Ub	Bending half number of samples	$\phi$ 0,7 mm; load 5N; 4 x 90°	
	Uc	Torsion other half number of samples	3 x 360° in opposite directions	no damage $\Delta R$ max. 0,25% + 0,05 $\Omega$
19	T	Soldering	solderability: 2 s 230 °C, flux 600 thermal shock: 3 s 350 °C, 6 mm from body	good tinning no damage $\Delta R$ max. 0,25% + 0,05 $\Omega$
20	Na	Rapid change of temperature	$\frac{1}{2}$ h $-55$ °C/ $\frac{1}{2}$ h $+155$ °C, 5 cycles	$R \leq 1$ M $\Omega$ : $\Delta R$ max. 0,25% + 0,05 $\Omega$ $R > 1$ M $\Omega$ : $\Delta R$ max. 0,5% + 0,05 $\Omega$
22	Fc	Vibration	frequency 10-500 Hz, displacement 1,5 mm or acceleration 10g, three directions; total 6 h (3 x 2 h)	no damage $\Delta R$ max. 0,25% + 0,05 $\Omega$
21	Eb	Bump	3 x 1500 bumps in three directions, 40g	no damage $\Delta R$ max. 0,25% + 0,05 $\Omega$

IEC 115-1 clause	IEC 68 test method	test	procedure	requirements
23		Climatic sequence		
23.2	Ba	Dry heat	16 h, 155 °C	
23.3	D	Damp heat (accel) 1st cycle	24 h; 55 °C; 95-100% R.H.	
23.4	Aa	Cold	2 h; -55 °C	
23.5	M	Low air pressure	2 h; 85 kPa; 15-35 °C	
23.6	D	Damp heat (accel) remaining cycles	5 days; 55 °C; 95-100% R.H.	R <sub>ins</sub> min. 1000 MΩ R ≤ 1 MΩ: ΔR max. 1% + 0,05 Ω R > 1 MΩ: ΔR max. 2% + 0,1 Ω
24.2	Ca	Damp heat steady state	56 days; 40 °C; 90-95% R.H. dissipation 0,01 P <sub>n</sub>	R <sub>ins</sub> min. 1000 MΩ R ≤ 1 MΩ: ΔR max. 1% + 0,05 Ω R > 1 MΩ: ΔR max. 2% + 0,1 Ω
26.2	—	Endurance	1000 hours; 70 °C; nominal dissipation or V <sub>max</sub>	R ≤ 1 MΩ: ΔR max. 1% + 0,05 Ω R > 1 MΩ: ΔR max. 2% + 0,1 Ω
11	—	Temperature coefficient	between -55 °C and + 155 °C	R ≤ 1 MΩ: ≤ 100.10 <sup>-6</sup> /K R > 1 MΩ: ≤ 250.10 <sup>-6</sup> /K
10	—	Voltage proof on insulation	700 V (r.m.s.) 1 minute	no breakdown
14	—	Noise	IEC publication 195	R ≤ 1 MΩ: max. 0,1 μV/V R > 1 MΩ: max. 1,5 μV/V
9	—	Insulation resistance		min. 10 <sup>4</sup> MΩ
15	—	Short time overload	Room temperature, dissipation 6,25 P <sub>n</sub> (voltage not more than 2 x limiting voltage), 10 cycles 5 s on, 45 s off	ΔR max. 1% + 0,05 Ω



PACKAGING

The resistors are supplied on bandolier; either 1000 resistors in ammopack or 5000 resistors on reel.

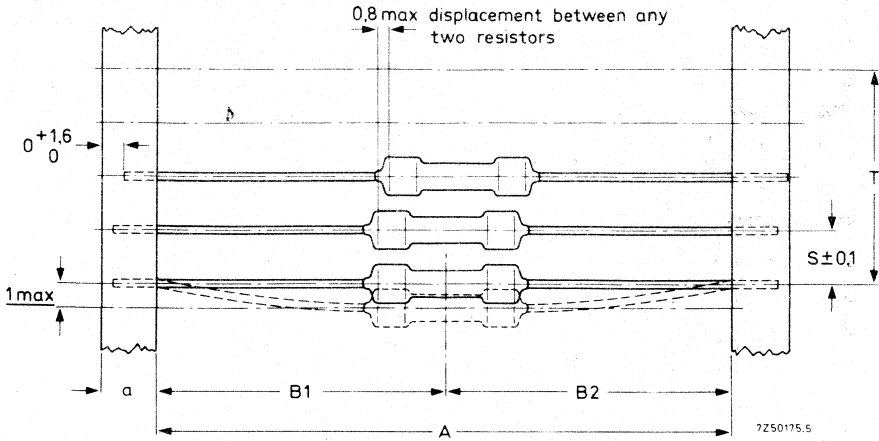

Fig. 2.

type	a $\pm 0,5$	A $\pm 1,5$	B1-B2 $\pm \text{max.}$	S (spacing) 5	T (max. deviation of spacing) 1 mm per 10 spacings 0,5 mm per 5 spacings
SFR30	6	52,5	1,2	5	1 mm per 10 spacings 0,5 mm per 5 spacings

Reel dimensions

type	quantity	A	B
SFR30	5000	75	356

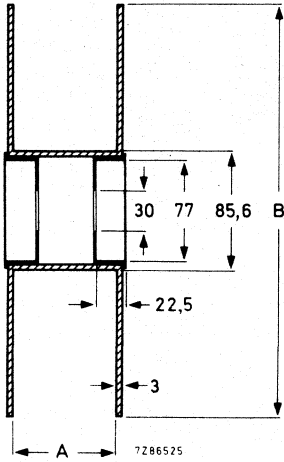

Fig. 3 Length of leader at beginning and end (bandolier without resistors) is 300 mm.

## FUSIBLE RESISTORS

metal film

### QUICK REFERENCE DATA

Resistance range	1 $\Omega$ to 15 k $\Omega$ , E24 series		
Resistance tolerance	$\pm 5\%$		
Temperature coefficient	$\leq 100 \cdot 10^{-6}/K$		
Absolute maximum dissipation at $T_{amb} = 70 \text{ }^\circ\text{C}^*$	NFR25	0,33 W	
	NFR30	0,50 W	
Basic specifications	IEC 115-1 and 115-2		
Climatic category (IEC 68)	55/155/56		
Stability after	NFR25	NFR30	
endurance test	$\Delta R/R$ max.	1% + 0,05 $\Omega$	1% + 0,05 $\Omega$
climatic tests	$\Delta R/R$ max.	1% + 0,05 $\Omega$	1% + 0,05 $\Omega$
soldering	$\Delta R/R$ max.	0,25% + 0,05 $\Omega$	0,25% + 0,05 $\Omega$

### APPLICATION

These resistors have been designed to meet the safety requirements in audio and video applications, in circuits where protection against overloads is needed, e.g. in power supply circuits. The resistors will become open circuited within a certain range of overload, without the risk of fire (see Figs 2 and 5).

### DESCRIPTION

A homogenous film of metal alloy is deposited on a high grade ceramic body. After a helical groove has been cut in the resistive layer, tinned connecting wires of electrolytic copper are welded to the end-caps. The resistors are coated with a grey flame retardant lacquer which provides electrical, mechanical and climatic protection. The encapsulation is resistant to all cleaning solvents commonly used for printed-wiring boards.

### MECHANICAL DATA

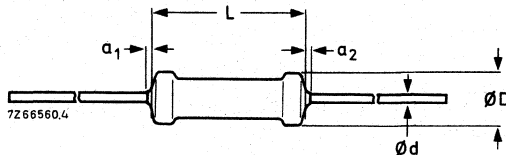

Fig. 1.

type	$D_{max}$	$L_{max}$	d	$a_1 + a_2$
NFR25	2,5	6,5	0,6	$\leq 1$
NFR30	3,0	8,5	0,7	$\leq 1$

\* This is the dissipation at  $T_{amb} = 70 \text{ }^\circ\text{C}$  which causes the maximum permissible hot-spot temperature of 155  $^\circ\text{C}$  to occur, irrespective of the resistance drift provoked by this condition.

# NFR25 NFR30

The length of the body is measured by inserting the leads into holes of two identical gauge plates and moving these plates parallel to each other until the resistor body is clamped without deformation (IEC publication 294). For leads of 0,6 and 0,7 mm diameter of the holes in the gauge plate is 1,0 mm.

## Mass

NFR25	25 g per 100
NFR30	33 g per 100

## Mounting

The resistors are suitable for processing on automatic insertion equipment and cutting and bending machines.

Since these resistors are used in applications where overloads can occur, it is not advisable to mount the resistors against other components or against printed circuit boards.

## Marking

The nominal resistance and the tolerance are marked on these resistors by means of four coloured bands according to IEC publication 62 "Colour code for fixed resistors". See also General Section.

## ELECTRICAL DATA

### Standard values of rated resistance and tolerance

Standard values of rated resistance (nominal resistance) are taken from the E24 series within the range 1  $\Omega$  to 15 k $\Omega$ . E24 series of values is given in the table "Standard series of values in a decade" at the back of this book. The tolerance on the rated resistance is  $\pm 5\%$ .

The limiting voltage (r.m.s.) for element and insulation is the maximum voltage that may be applied continuously to the resistor element or the insulation. See IEC publications 115-1 and 115-2. This voltage is 250 V for NFR25 and 350 V for NFR30.

### Composition of the catalogue number

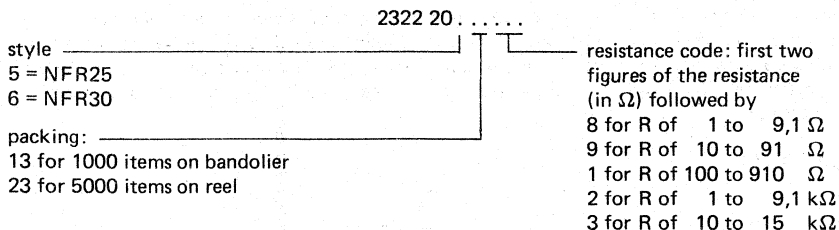

### Example

The catalogue number of a resistor NFR25 of 5600  $\Omega$ , taped on a bandolier of 1000 items, supplied in ammopack, is 2322 205 13562.

Time to interruption as a function of overload

"Interruption" means that the nominal resistance has increased at least 10 times.

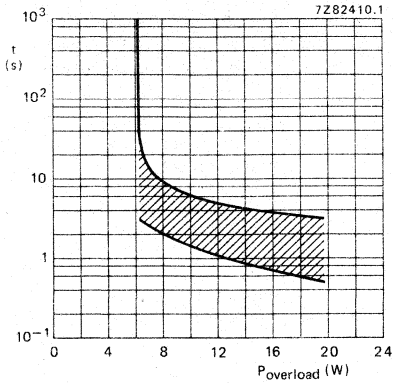

Fig. 2 NFR25;  $R \leq 15 \Omega$ .

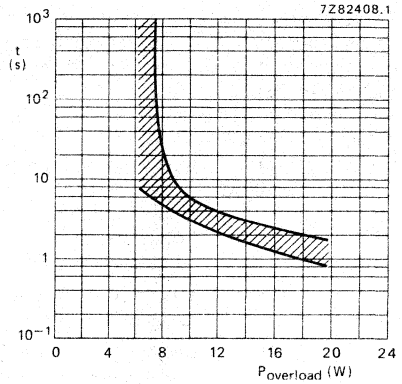

Fig. 3 NFR25;  $15 \Omega < R \leq 100 \Omega$ .

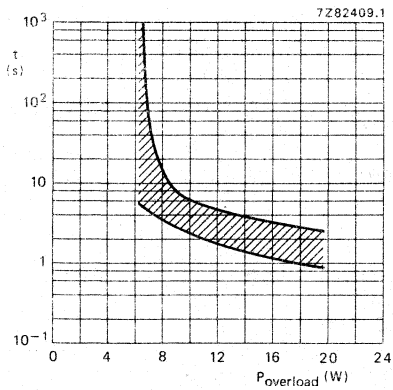

Fig. 4 NFR25;  $R > 100$ .

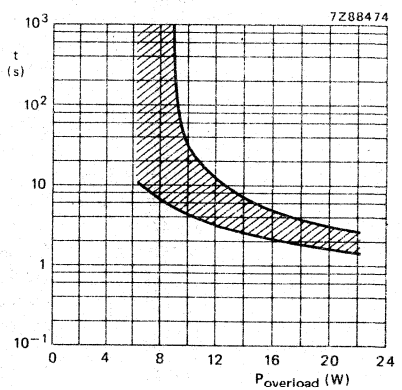

Fig. 5 NFR30.



**TESTS AND REQUIREMENTS**

Essentially all tests are carried out according to the schedule of IEC publication 115-1, category 55/155/56 (rated temperature range -55 to + 155 °C; damp heat, long term, 56 days) and along the lines of IEC publication 68, "Recommended basic climatic and mechanical robustness testing procedure for electronic components". In the following table the tests are listed with reference to the relevant clauses of IEC publications 115-1 and 68; a short description is also given of the test procedure and requirements. In some instances deviations from the IEC recommendation were necessary for our method of specifying. For inflammability requirements reference is made to U.L. publication 1412 and to CECC.

IEC 115-1 clause	IEC 68 test method	test	procedure	requirements
18	Ua	Robustness of terminations Tensile all samples	load 10 N, 10 s	number of failures < 10 ppm  no damage ΔR max. 0,25% + 0,05 Ω
	Ub	Bending half number of samples	load 5 N, 4 x 90°	
	Uc	Torsion other half number of samples	3 x 360° in opposite directions	
19	T	Soldering	solderability: 2 s 230 °C, flux 600  thermal shock: 3 s 350 °C, 6 mm from body	good tinning no damage ΔR max. 0,25% + 0,05 Ω
20	Na	Rapid change of temperature	½ h -55 °C/½ h + 155 °C 5 cycles	ΔR max. 0,25% + 0,05 Ω
22	Fc	Vibration	frequency 10-500 Hz, displacement 1,5 mm or acceleration 10g, three directions; total 6 h (3 x 2 h)	no damage ΔR max. 0,25% + 0,05 Ω
21	Eb	Bump	3 x 1500 bumps in three directions, 40g	no damage ΔR max. 0,25% + 0,05 Ω



IEC 115-1 clause	IEC 68 test method	test	procedure	requirements
23		Climatic sequence		
23.2	Ba	Dry heat	16 h; 155 °C	
23.3	D	Damp heat (accel) 1st cycle	24 h; 55 °C; 95-100% R.H.	
23.4	Aa	Cold	2 h; -55 °C	
23.5	M	Low air pressure	2 h; 8,5 kPa; 15-35 °C	
23.6	D	Damp heat (accel) remaining cycles	5 days; 55 °C; 95-100% R.H.	$R_{ins}$ min. 1000 M $\Omega$ $\Delta R$ max. 1,0% + 0,05 $\Omega$
24.2	Ca	Damp heat (steady state)	56 days; 40 °C; 90-95% R.H. dissipation 0,01P <sub>n</sub>	$R_{ins}$ min. 1000 M $\Omega$ $\Delta R$ max. 1,0% + 0,05 $\Omega$
26.2	—	Endurance	1000 hours; 70 °C; nominal dissipation or V <sub>max</sub>	$\Delta R$ max. 1,0% + 0,05 $\Omega$
11	—	Temperature coefficient	between -55 °C and + 155 °C	$\leq 100 \cdot 10^{-6}/K$
10	—	Voltage proof on insulation	700 V (r.m.s.) 1 minute	no breakdown
14	—	Noise	IEC publication 195	< 0,1 $\mu V/V$
9	—	Insulation resistance		min. 10 <sup>4</sup> M $\Omega$



PACKAGING

The resistors are supplied on bandolier; either 1000 resistors in ammpack or 5000 resistors on reel.

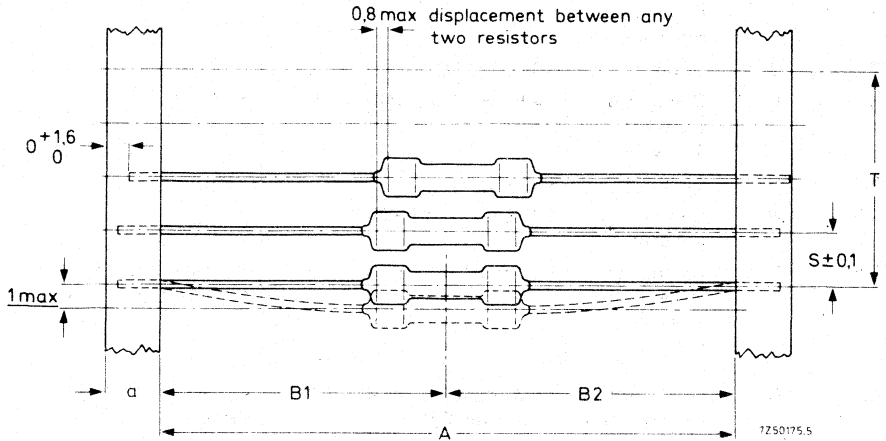

Fig. 6.

type	a ± 0,5	A ± 1,5	B1 - B2 ± max.	S (spacing)	T (max. deviation of spacing)
NFR25	6	52,5	1,2	5	} 1 mm per 10 spacings, 0,5 mm per 5 spacings
NFR30	6	52,5	1,2	5	



Reel dimensions

type	quantity	A	B
NFR25	5000	75	305
NFR30	5000	75	356

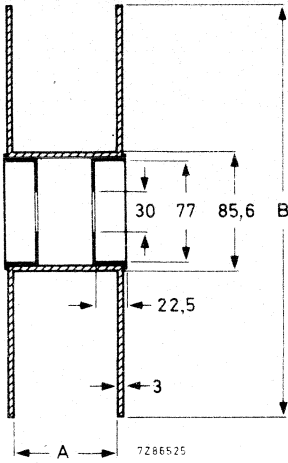

Fig. 7.





## METAL FILM RESISTORS



## QUICK REFERENCE DATA

Type	MR16	MR25	MR30	MR52
Resistance range	10 $\Omega$ to 100 k $\Omega$	1 $\Omega$ to 1 M $\Omega$	1 $\Omega$ to 1 M $\Omega$	4,99 $\Omega$ to 1 M $\Omega$
Series	E24; E96	E192; E24; E96	E24; E96	E96
Resistance tolerance	$\pm 1\%$ ; $\pm 2\%$	$\pm 0,5\%$ ; $\pm 1\%$ ; $\pm 2\%$	$\pm 0,5\%$ ; $\pm 1\%$ ; $\pm 2\%$	$\pm 1\%$
Temperature coefficient	$\pm 50 \cdot 10^{-6}/K$	$\pm 50 \cdot 10^{-6}/K$	$\pm 50 \cdot 10^{-6}/K$	$\pm 100 \cdot 10^{-6}/K$
Absolute max. dissipation at $T_{amb} = 70 \text{ }^\circ\text{C}$	0,25 W	0,4 W	0,5 W	1 W
Basic specification		IEC 115-1		
Climatic category (IEC 68)		55/155/56		
Approval		 CECC 40101		
Stability after				
load		$\Delta R/R$ see nomogram		
climatic tests		$\Delta R/R$ max. 0,5% + 0,05 $\Omega$		
soldering		$\Delta R/R$ max. 0,1% + 0,01 $\Omega$		
short time overload		$\Delta R/R$ max. 0,25% + 0,05 $\Omega$		

## APPLICATION

For use in professional equipment: computers, telecom, measuring, etc.

## DESCRIPTION

A homogeneous film of metal alloy is deposited on a high grade ceramic body. After a helical groove has been cut in the resistive layer, tinned connecting wires of electrolytic copper are welded to the end-caps. The resistors are coated with layers of green lacquer which provides electrical, mechanical and climatic protection. The encapsulation is resistant to all cleaning solvents commonly used for printed-wiring boards.

## MECHANICAL DATA

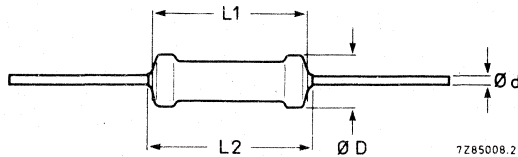

Fig. 1 This standard version is specially made to obtain a minimum "clean lead to clean lead" dimension L2.

Table 1

type	$D_{max}$	$L1_{max}$	$L2_{max}$	d
MR16	1,6	4,0	5,0	0,5
MR25	2,5	6,5	7,5	0,6
MR30	3,0	10,0	11,0	0,6
MR52	5,2	16,5	17,5	0,6

\* Dissipation at  $T_{mab} = 70 \text{ }^\circ\text{C}$  which causes the maximum permissible hot-spot temperature of 175  $^\circ\text{C}$  to occur, irrespective of the resistance drift provoked by this condition.

MR16  
MR30

MR25  
MR52

The length of the body is measured by inserting the leads into the holes of two identical gauge plates and moving these plates parallel to each other until the resistor body is clamped without deformation (IEC publication 294). For leads of 0,5 mm dia the diameter of the holes in the gauge plate is 0,8 mm and for leads of 0,6 mm dia these holes are 1,0 mm dia.

#### Mass

type MR16 : 8 g per 100  
MR25 : 25 g per 100  
MR30 : 32 g per 100  
MR52 : 92 g per 100

#### Mounting

The resistors are suitable for processing an automatic insertion equipment and cutting and bending machines.

#### Marking

The nominal resistance and the tolerance are marked on the resistors by four or five coloured bands according to IEC publication 62 "Colour code for fixed resistors".  
See General Section.

### ELECTRICAL DATA

#### Standard values of rated resistance and tolerance

Standard values of rated resistance (nominal resistance) are taken from the E24 series for resistors with a tolerance of  $\pm 2\%$ , from E24/E96 series for  $\pm 1\%$  and from the E192 series for  $\pm 0,5\%$ . The values of these series are given in the table "Standard series of values in a decade" at the back of the handbook. The limiting voltage (r.m.s.) for resistor element and insulation is the maximum voltage that may be applied continuously to the resistor element or the insulation. See IEC publication 115-1 and 115-2.

Table 2

type	packing	quantity	resistance range	tol. %	series	temp. coefficient $\cdot 10^{-6}/K$	limiting voltage V	catalogue number 2322 followed by:
MR16	ammopack	1000	10 $\Omega$ to 100 k $\Omega$	1	E24/96	50	150	150 5....
				2	E24			150 4....
	reel	5000		1	E24/96			150 2....
				2	E24			150 1....
MR25	ammopack	1000	1 $\Omega$ to 1 M $\Omega$	0,5	E192	50*	250	151 7....
				1	E24/96			151 5....
		2		E24	151 4....			
		5000		1	E24/96			151 8....
	2			E24	154 1....			
	(26 mm) reel	2000		1	E24/96			154 0....
				1	E24/96			151 2....
		5000		2	E24			151 1....
2			E24	152 1....				
M30	ammopack	1000	1 $\Omega$ to 1 M $\Omega$	0,5	E192	50*	350	152 7....
				1	E24/96			152 5....
	reel	5000		2	E24			152 4....
				1	E24/96			152 2....
M52	ammopack	1000	4,99 $\Omega$ to 1 M $\Omega$	2	E24	100	500	152 1....
				1	E96			153 5....

## COMPOSITION OF THE CATALOGUE NUMBER

The catalogue number in the above table is completed by inserting the resistance code: the first three figures of the resistance in  $\Omega$  followed by

8 for R = 1 to 9,76  $\Omega$

9 for R = 10 to 97,6  $\Omega$  (see note)

1 for R = 100 to 976  $\Omega$

2 for R = 1 to 9,76 k $\Omega$

3 for R = 10 to 97,6 k $\Omega$

4 for R = 100 to 976 k $\Omega$

5 for R = 1 M $\Omega$

Example: the catalogue number of a resistor  
M25 of 3650  $\Omega \pm 1\%$  in ammpack of 1000 is  
2322 151 53652

## Note

The composition of catalogue number is not applicable for R = 49,9  $\Omega$  the relevant catalogue numbers will be indicated on request.

\* For R < 4,99  $\Omega$  :  $100 \cdot 10^{-6}/K$ .

**DISSIPATION AND STABILITY**

The stability as a function of dissipation and ambient temperature is indicated in the performance nomogram of Fig. 2.

**Notes on nomogram**

1. It cannot be used for MR16.
2. It should not be extended beyond the maximum permissible hot-spot temperature of 175 °C.
3. The change in resistance for P = 0 at a particular ambient temperature is indicative for the shelf-life stability of a resistor at that temperature.
4. The stability lines do not give exact values of  $\Delta R/R$  but represent a probability of 95% that the actual values will be smaller than those obtained from the nomogram.
5. The limiting voltage has not been taken into consideration.

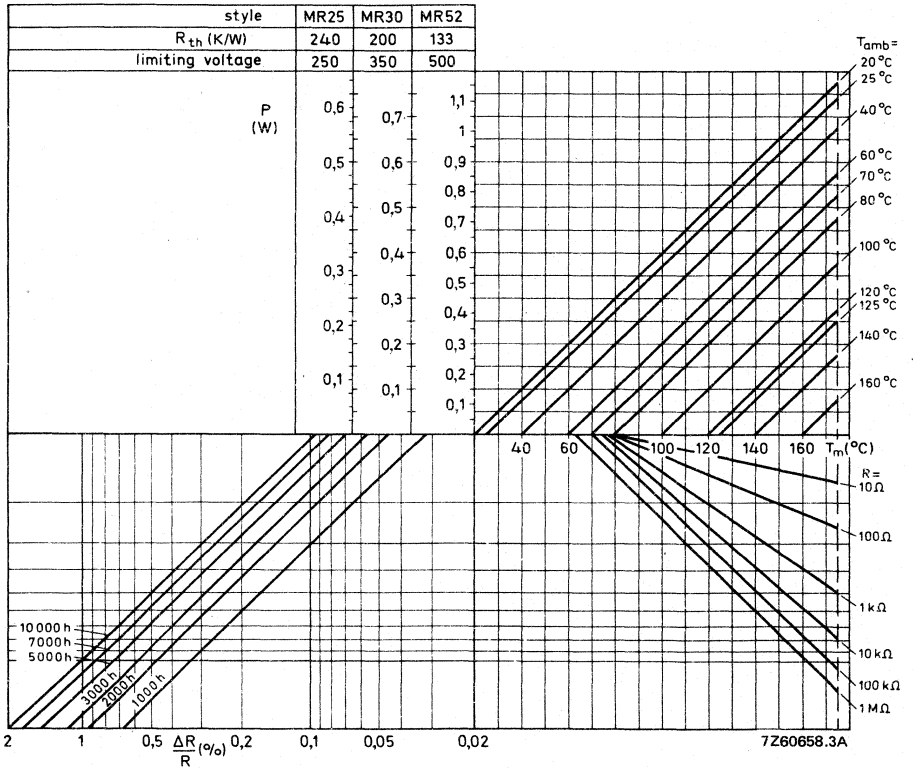

Fig. 2 Performance nomogram for different styles of resistor, showing the relationship between power dissipation P, ambient temperature  $T_{amb}$ , hot-spot temperature ( $T_m$ ) and max. resistance drift  $\Delta R/R$  after 1000 to 10 000 hours of operation.

## TESTS AND REQUIREMENTS

Essentially all tests are carried out according to the schedule of IEC publication 115-1, category 55/155/56 (rated temperature range  $-55$  to  $+155$  °C, damp heat, long term, 56 days) are carried out along the lines of IEC publication 68, "Recommended basic climatic and mechanical robustness testing procedure for electronic components". In the following table the tests are listed with reference to the relevant clauses of IEC publications 115-1 and 68; a short description is also given of the test procedure and requirements. In some instances deviations from the IEC specification were necessary for our method of specifying.

Table 3

IEC 115-1 clause	IEC 68 test method	test	procedure	requirements
18	Ua Ub Uc	Robustness of terminations Tensile all samples Bending half number of samples Torsion other half number of samples	load 10 N, 10 s load 5 N, $4 \times 90^\circ$ (MR16: load 2,5 N, $4 \times 90^\circ$ ) $3 \times 360^\circ$ in opposite directions	no damage $\Delta R$ max. 0,1% + 0,01 $\Omega$
19	T	Soldering	solderability: 2 s 230 °C, flux 600 thermal shock: 3 s. 350 °C, 6 mm from body	good tinning no damage $\Delta R$ max. 0,1%
20	Na	Rapid change of temperature	$\frac{1}{2}$ h $-55$ °C/ $\frac{1}{2}$ h $+155$ °C, 5 cycles	$\Delta R$ max. 0,1% + 0,01 $\Omega$
22	Fc	Vibration	frequency 10-500 Hz, displacement 1,5 mm or acceleration 10g, three directions; total 6 h	no damage $\Delta R$ max. 0,1% + 0,01 $\Omega$
21	Eb	Bump	$3 \times 1500$ bumps in three directions, 40g	no damage $\Delta R$ max. 0,1% + 0,01 $\Omega$ MR16, for $R \leq 100 \Omega$ : $\Delta R$ max. 0,5% + 0,05 $\Omega$

Table 3 (continued)

IEC 115-1 clause	IEC68 test method	test	procedure	requirements
23		Climatic sequence		
23.2	B	Dry heat	16 h; 155 °C	
23.3	D	Damp heat (accel) 1st cycle	24 h; 55 °C; 95-100% R.H.	
23.4	Aa	Cold	2 h; -55 °C	
23.5	M	Low air pressure	1 h; 8,5 kPa; 15-35 °C	
23.6	D	Damp heat (accel) remaining cycles	5 days; 55 °C; 95-100% R.H.	$R_{ins}$ min. 1000 M $\Omega$ $\Delta R$ max. 0,5% + 0,05 $\Omega$
24	Ca	Damp heat (long-term exposure)	56 days; 40 °C; 90-95% R.H. dissipation: MR16: $\leq 1,25$ mW MR25: $\leq 2,5$ mW MR30: $\leq 3$ mW MR52: $\leq 5$ mW	$R_{ins}$ min. 1000 M $\Omega$ $\Delta R$ max. 1,0% + 0,05 $\Omega$ } $\Delta R$ max. 0,5% + 0,05 $\Omega$
26.2	-	Endurance	1000 h: 70 °C: dissipation: MR16: 0,125 W MR25: 0,25 W MR30: 0,3 W MR52: 0,45 W } or $V_{max}$	$\Delta R$ max. 0,5% + 0,05 $\Omega$
11	-	Temperature coefficient	between -55 °C and + 155 °C	$\leq 50 \cdot 10^{-6}/K$ MR52: $\leq 100 \cdot 10^{-6}/K$
13	-	Voltage proof	2 x limiting voltage (a.c.) with a maximum of 750 V (r.m.s.)	no breakdown
14	-	Noise	IEC publication 195 MR16: $R \leq 68$ k $\Omega$ $R > 68$ k $\Omega$ MR25 } $R \leq 100$ k $\Omega$ MR30 } $R > 100$ k $\Omega$ MR52 }	max. 0,1 $\mu V/V$ max. 0,5 $\mu V/V$ max. 0,25 $\mu V/V$ max. 0,5 $\mu V/V$
9	-	Insulation resistance		min. 10 <sup>4</sup> M $\Omega$
15	-	Short-time overload	$T_{amb} = 25$ °C dissipation 6,25 x $P_{nom}$ voltage $\leq 2$ x limiting voltage 10 cycles: 5 s on - 4 s off	$\Delta R$ max. 0,25% + 0,05 $\Omega$



**PACKAGING**

The resistors are supplied on bandolier; either in ammopack or on reel, see Table 2.

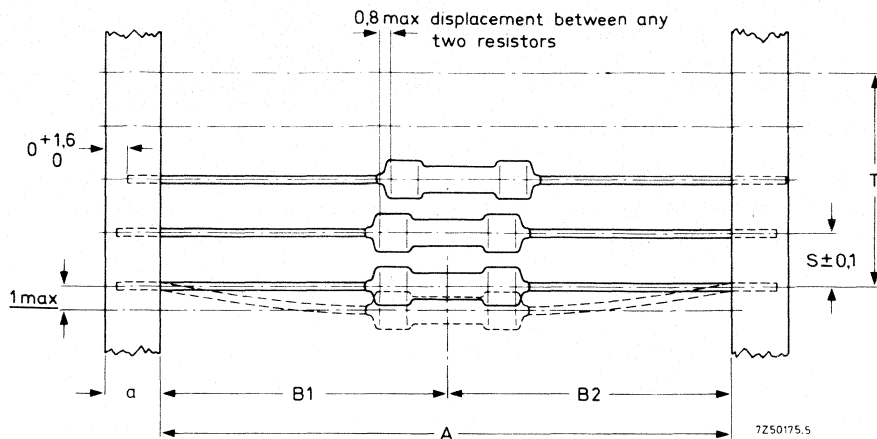

Table 3

type	a	A	B1 - B2 $\pm$ max.	S (spacing)	T (max. deviation of spacing)
MR16	$6 \pm 0,5$	$52,4 \pm 1,5$	1,2	5	1 mm per 10 spacings, 0,5 mm per 5 spacings
MR25	$6 \pm 0,5$	$52,4 \pm 1,5$	1,2	5	
MR25 on 26 mm bandolier	$6 \pm 0,5$	$26,0 \pm 1,5$	1,0	5	
MR30	$6 \pm 0,5$	$52,4 \pm 1,5$	1,2	5	
MR52	$6 \pm 0,5$	$66,7 \pm 1,5$	1,2	10	



MR16  
MR30

MR25  
MR52

Reel dimensions

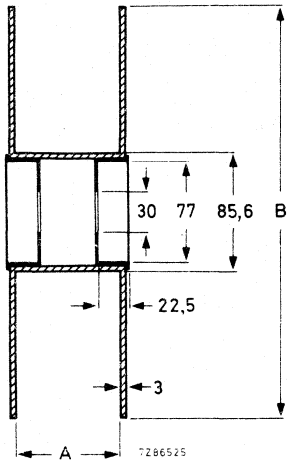

type	quantity	A	B
MR16	5000	75	305
MR25	5000	75	305
MR30	5000	75	365
MR52	—	—	—

Length of leader at beginning and end  
(bandolier without resistors) : 300 mm.



## LACQUERED METAL FILM RESISTORS

according to MIL-R-10509F

### QUICK REFERENCE DATA

Resistance range	10 $\Omega$ to 1 M $\Omega$ , E96 and E192 series	
Resistance tolerance	$\pm 0,1; 0,25; 0,5; 1\%$	
Rated dissipation at $T_{amb} = 70\text{ }^{\circ}\text{C}$	MR24D	0,125 W
	MR34D	0,25 W
	MR54D	0,5 W
	MR74D	0,75 W
$T_{amb} = 125\text{ }^{\circ}\text{C}$	MR24E/C	0,1 W
	MR34E/C	0,125 W
	MR54E/C	0,25 W
	MR74E/C	0,5 W
Basic specification	MIL-R-10509F	
Stability after		
load	$\Delta R/R$	max. 0,5% +0,05 $\Omega$
climatic tests	$\Delta R/R$	max. 0,5% +0,05 $\Omega$
soldering	$\Delta R/R$	max. 0,1% +0,05 $\Omega$
short-time overload	$\Delta R/R$	max. 0,25% +0,05 $\Omega$

### APPLICATION

For use in professional equipment: computers, telecom, measuring, etc.

### DESCRIPTION

A homogeneous film of metal alloy is deposited on a high grade ceramic body. After a helical groove has been cut in the resistive layer, tinned connecting wires of electrolytic copper are welded to the end-caps. The resistors are coated with layers of green lacquer which provide electrical, mechanical and climatic protection. The encapsulation is resistant to all cleaning solvents commonly used for printed wiring boards.

### MECHANICAL DATA

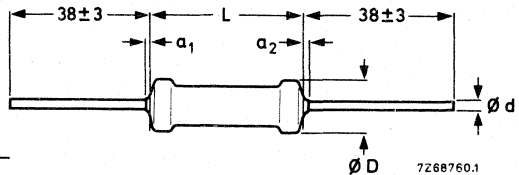

Fig. 1.

Table 1

type	$D_{max}$	$L_{max}$	$a_1, a_2$ $a_1 + a_2$	d
MR24E/C/D	2,4	6,5	$\leq 1$	0,6
MR34E/C/D	3,1	10,5	$\leq 1$	0,6
MR54E/C/D	5,2	16,5	$\leq 1$	0,6
MR74E/C/D	6,8	20,5	$\leq 1$	0,8

The length of the body is measured by inserting the leads into the holes of two identical gauge plates and by moving these plates parallel to each other until the resistor body is clamped without deformation (see IEC publication 294). For leads of 0,6 mm diameter the diameter of the holes in the gauge plate is 1,0 mm and for leads of 0,8 mm these holes are 1,2 mm diameter.

#### Mass

MR24E/C/D	25 g per 100
MR34E/C/D	32 g per 100
MR54E/C/D	92 g per 100
MR74E/C/D	200 g per 100

#### Mounting

The resistors must be mounted stress free so as to allow thermal expansion over the wide permissible temperature range.

#### Marking

The resistors are marked according to the MIL specification MIL-R-10509F. This means that the following information is printed on the resistor:

MIL style

Value and tolerance in MIL code

Manufacturers' identification symbol.

In the MIL code for value and tolerance the value is indicated by four figures and a letter: first the three significant figures according to the E192 or E96 series, a fourth figure indicating the number of zeros to follow and then a letter indicating the tolerance as follows:

B =  $\pm 0,1\%$ ; C =  $\pm 0,25\%$ ; D =  $\pm 0,5\%$  and F =  $\pm 1\%$ .

Example: 22,1 k $\Omega$   $\pm 1\%$  is written as 2212 F.

This code should not be used for ordering. Please use the catalogue number (see next page) for this purpose.

#### ELECTRICAL DATA

##### Standard values of rated resistance and tolerance

Standard values of rated resistance (nominal resistance) are taken from the E96 series for resistors with a tolerance of  $\pm 1\%$ , from the E192 series for resistors with a tolerance of  $\pm 0,5\%$ ,  $\pm 0,25\%$  or  $\pm 0,1\%$  (MIL-R-10509F para 1.2.1.3). Resistors with a tolerance of  $\pm 0,1\%$  and  $\pm 0,25\%$  may also be requested with resistance values deviating from the E192 series, provided the value can be indicated with no more than three significant figures. The values of the E96 and E192 series are given at the back of this book.

Table 2

style	rated dissipation W	maximum temperature coefficient $\cdot 10^{-6}/K$	resistance range and tolerance	max. voltage V rms	MIL style	catalogue number 2322 followed by
	at 125 °C	±	0,1/0,25/0,5% E192 series 1% E96 series			
MR24E	0,1	25	49,9 Ω to 1 MΩ	200	RN55E	160 .....
MR24C	0,1	50	49,9 Ω to 1 MΩ	200	RN55C	161 .....
MR34E	0,125	25	49,9 Ω to 1 MΩ	250	RN60E	163 .....
MR34C	0,125	50	49,9 Ω to 1 MΩ	250	RN60C	164 .....
MR54E	0,25	25	49,9 Ω to 1 MΩ	300	RN65E	166 .....
MR54C	0,25	50	49,9 Ω to 1 MΩ	300	RN65C	167 .....
MR74E	0,5	25	24,9 Ω to 1 MΩ	350	RN70E	169 .....
MR74C	0,5	50	24,9 Ω to 1 MΩ	350	RN70C	170 .....
	at 70 °C	±	1% E96 series			
MR24D	0,125	100	10 Ω to 1 MΩ	200	RN55D	162 .....
MR34D	0,25	100	10 Ω to 1 MΩ	300	RN60D	165 .....
MR54D	0,5	100	10 Ω to 1 MΩ	350	RN65D	165 .....
MR74D	0,75	100	10 Ω to 1 MΩ	500	RN70D	171 .....

## COMPOSITION OF THE CATALOGUE NUMBER

The catalogue number in the above table is completed by inserting the tolerance and resistance code:

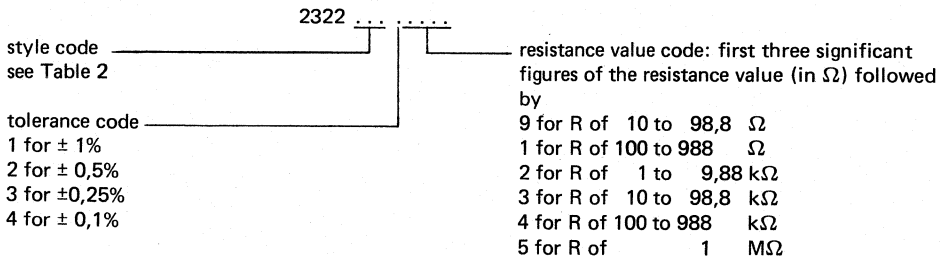

For the resistance values mentioned in Table 3 the "Composition of the catalogue number" is not applicable. In this table the last 5 digits of the catalogue number are stated in full.

Table 3

resistance value $\Omega$	last 5 digits of the catalogue number			
	0,1%	0,25%	0,5%	1%
29,9	92102	92122		
39,9	92103	92123		
49,9	92104	92124	92134	92144
59,9	92105	92125		
69,9	92106	92126		
79,9	92107	92127		
89,9	92108	92128		
99,9	92109	92129		

**TESTS AND REQUIREMENTS**

All tests are carried out according to the schedule of MIL-R-10509F para 4.4.2. In the table below the tests and requirements are listed with reference to the relevant paragraphs of this specification.

Table 4

MIL method			requirement	
R 10509F paragraph	STD 202 method	procedure	MIL-R-10509F paragraph	requirement*
4.6.4	102	Temperature cycling	3.9	$\Delta R \leq 0,25\% + 0,05 \Omega$
4.6.5	—	Low-temperature operation	3.10	$\Delta R \leq 0,25\% + 0,05 \Omega$
4.6.6	—	Short-time overload	3.11	$\Delta R \leq 0,25\% + 0,05 \Omega$
4.6.7	211	Terminal strength	3.12	$\Delta R \leq 0,2\% + 0,05 \Omega$
4.6.8	301/105	Dielectric withstanding voltage	3.13	$\Delta R \leq 0,25\% + 0,05 \Omega$
4.6.9	302	Insulation resistance	3.14	$R_{ins} \geq 10\ 000\ M\Omega$
4.6.10	210	Resistance to soldering heat	3.15	$\Delta R \leq 0,1\% + 0,05 \Omega$
4.6.11	106	Moisture resistance	3.16	$\Delta R \leq 0,5\% + 0,05 \Omega$
4.6.13	108	Life	3.18	$R_{ins} \geq 100\ M\Omega$ $\Delta R \leq 0,5\% + 0,05 \Omega$
4.6.15	205	Shock, medium impact	3.20	$\Delta R \leq 0,25\% + 0,05 \Omega$
4.6.16	204	Vibration	3.21	$\Delta R \leq 0,25\% + 0,05 \Omega$

**PACKAGING**

Bulk packing, 100 per box.

\* Although resistors with a temperature coefficient of  $100 \cdot 10^{-6}/K$  correspond with characteristic D resistors of MIL-R-10509F, they meet the more severe test requirements of characteristic C and E resistors.

## METAL FILM PRECISION RESISTORS

### QUICK REFERENCE DATA

Resistance range		24 $\Omega$ to 100 k $\Omega$	4,99 $\Omega$ to 1 M $\Omega$
Resistance tolerance		$\pm 0,05; 0,02; 0,01\%$	$\pm 0,5; 0,25; 0,1\%$
Category		25/125/56	55/155/56
Failure level		S	R
Absolute maximum dissipation at $T_{amb} = 70\text{ }^{\circ}\text{C}$	MPR24 MPR34	0,125 W 0,25 W	0,250 W 0,40 W
Specification based on		CECC 40300 MIL-R-10509 MIL-R-55182 DIN 44061 IEC 115-5	
Temperature characteristic between + 20 and + 70 $^{\circ}\text{C}$		$\Delta R/R$ max. $\pm 0,0025\%$ (TC 25) $\Delta R/R$ max. $\pm 0,0015\%$ (TC 15) $\Delta R/R$ max. $\pm 0,0010\%$ (TC 10) $\Delta R/R$ max. $\pm 0,0005\%$ (TC 5)	
Vibration test		10 Hz to 500 Hz; 0,75 mm or 98 m/s <sup>2</sup>	
Air pressure (lower limit)		8,5 kN/m <sup>2</sup>	
Stability after load		$\Delta R/R$ max. 0,05% + 0,01 $\Omega$	
climatic tests		$\Delta R/R$ max. 0,05% + 0,01 $\Omega$	
soldering test		$\Delta R/R$ max. 0,01% + 0,01 $\Omega$	
short overload		$\Delta R/R$ max. 0,01% + 0,01 $\Omega$	

### APPLICATION

These resistors have been developed for highly professional applications such as computers, test and telecommunication equipment, where high stability and low temperature coefficient are essential.

### DESCRIPTION

The resistor consists of a ceramic core with a vacuum-deposited chromium-nickel coating, provided with a metal cap on either end, to which leads are welded.

The resistor is coated with a green lacquer layer providing electrical, mechanical, chemical, and climatic protection.

MECHANICAL DATA

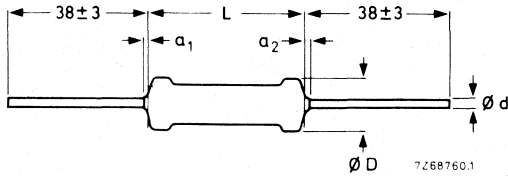

Fig. 1.

Table 1

type	D <sub>max</sub>	L <sub>max</sub>	a <sub>1</sub> + a <sub>2</sub>	d
MPR24	2,5	6,5	≤ 1	0,6
MPR34	3,0	10,0	≤ 1	0,6

The lead length (38 ± 3 mm) only applies to untaped resistors, i.e. those packed in a cassette. See Standard Packaging.

The length of the body is measured by inserting the leads into the 1 mm diameter holes of two identical gauge plates and by moving these plates parallel to each other until the resistor body is clamped without deformation (see IEC publication 294).

Mass (per 100 items): MPR24 – 25g  
MPR34 – 30g

Coding

The resistors are either colour-coded or marked. Any value within the range can be supplied colour-coded, provided the resistance can be expressed in 3 coloured bands according to IEC publication 62 "Colour code for fixed resistors". See also General Section. All other resistors, including those in cassette packing, are marked.

Colour coding

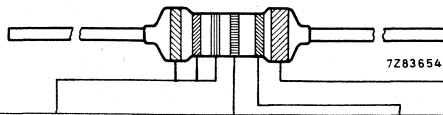

colour	significant figures	multiplier	tol. %	TC . 10 <sup>-6</sup> /K
black	0	1 x		
brown	1	10 x		
red	2	100 x		50
orange	3	1 000 x		15
yellow	4	10 000 x		25
green	5	100 000 x	± 0,5	
blue	6	1 000 000 x	± 0,25	10
violet	7		± 0,1	5
grey	8			
white	9			
silver	—	0,01 x		
gold	—	0,1 x		



**Marking**

When marked, the following details are printed on the resistors:

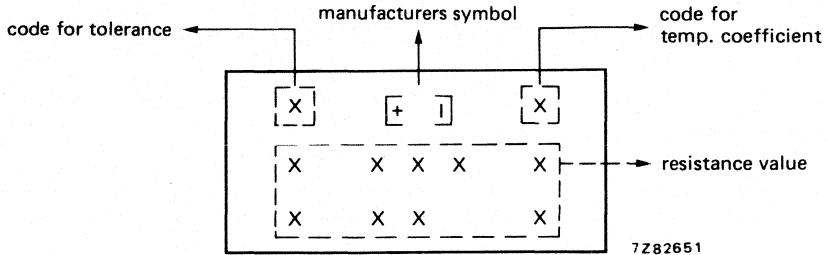

Tolerance: (acc IEC62).

- ± 0,5 % = D
- ± 0,25% = C
- ± 0,1 % = B
- ± 0,05% = W
- ± 0,02% = P
- ± 0,01% = L

Temperature coefficient:

- TC 25 = 1
- TC 15 = 2
- TC 10 - 3
- TC 5 = 4

Resistors with other temperature coefficients are available on request.

Resistance value:

Nine positions are available for the resistance value according to IEC 62.

- Example: 4R99 = 4,99 Ω
- K2751 = 275,1 Ω
- 27R83 = 27,83 Ω



**ELECTRICAL DATA**

Maximum permissible voltage: 250 V (d.c.). Insulation voltage: 500 V (d.c.)

Resistance range	24 $\Omega$ to 100 k $\Omega$	4,99 $\Omega$ to 1 M $\Omega$
Resistance tolerance	$\pm 0,05; 0,02; 0,01\%$	$\pm 0,5; 0,25; 0,1\%$
Climatic category (IEC68)	25/125/56	55/155/56
Failure level	S	R
Absolute maximum dissipation at $T_{amb} = 70\text{ }^{\circ}\text{C}$	MPR24 0,125 W MPR34 0,25 W	0,250 W 0,40 W
Temperature coefficient	5,10,15,25 $\cdot 10^{-6}/\text{K}$	5,10,15,25 $\cdot 10^{-6}/\text{K}$

Resistors in the range 24  $\Omega$  to 200  $\Omega$ , tolerance  $< 0,1\%$ , are of low inductance.

Derating at temperatures above 70  $^{\circ}\text{C}$

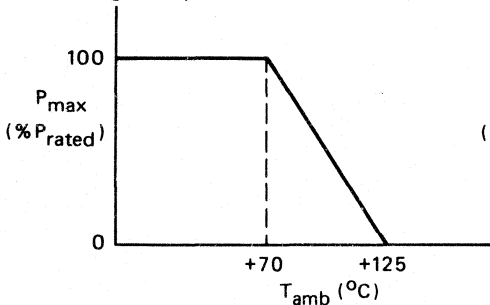

Fig. 2a Maximum dissipation ( $P_{max}$ ) as a function of  $T_{amb}$  for R tolerances of 0,05, 0,02 and 0,01%.

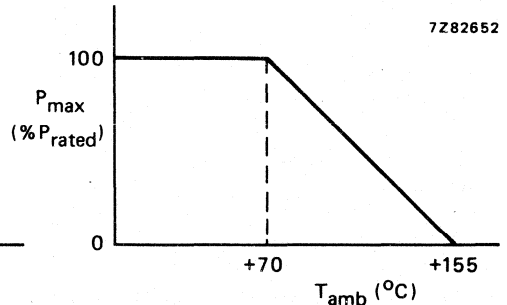

Fig. 2b Maximum dissipation ( $P_{max}$ ) as a function of  $T_{amb}$  for R tolerances of 0,5, 0,25 and 0,1%.

**Dissipation and stability**

The stability as a function of dissipation and ambient temperature is indicated in the performance nomogram of Fig. 3 for resistors with R tolerance  $\geq 0,1\%$ .

**Notes on nomogram**

1. The nomogram should not be extended beyond the maximum permissible hot-spot temperature of 175  $^{\circ}\text{C}$ .
2. The resistance change given by the nomogram for  $P = 0$  at a particular ambient temperature is indicative of the shelf-life stability of a resistor at that temperature.
3. The stability lines do not give exact values  $\Delta R/R$ , but represent a probability of 95% that the real values will be smaller than those obtained from the nomogram.
4. In the nomogram the limiting voltage of the resistors has not been taken into consideration.

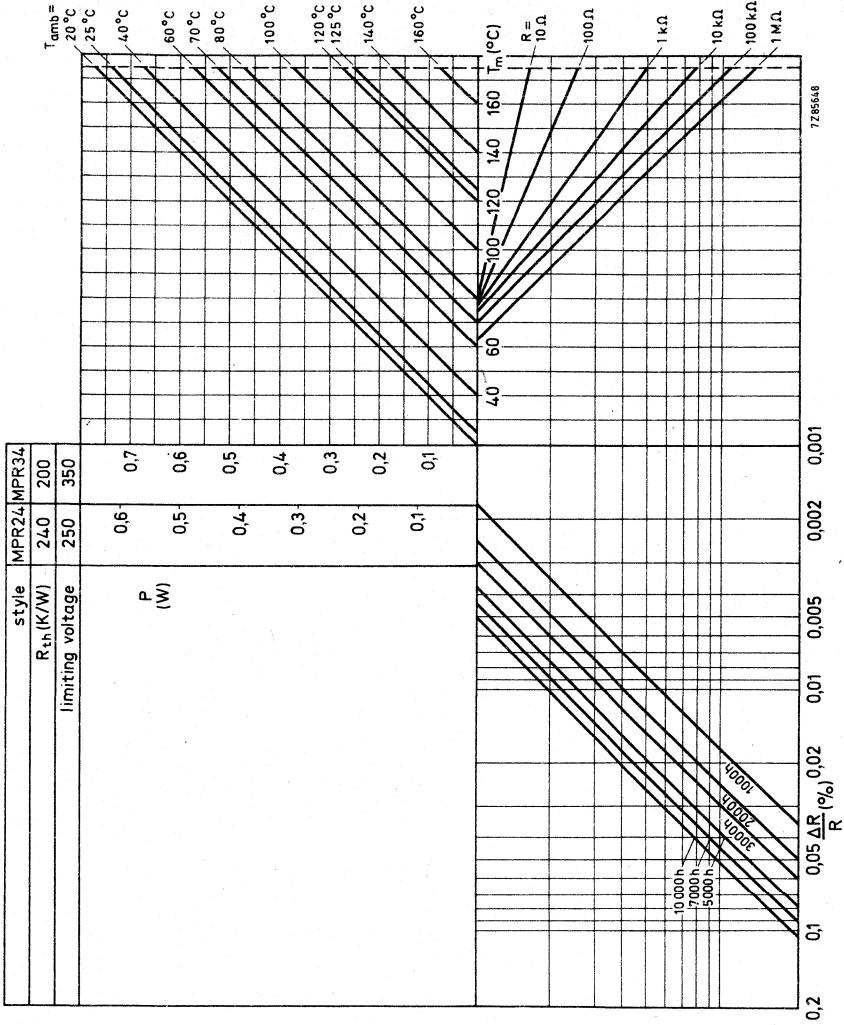

Fig. 3 Performance nomogram for different styles of resistor, showing the relationship between power dissipation  $P$ , ambient temperature  $T_{amb}$ , hot-spot temperature ( $T_m$ ) and max. resistance drift  $\Delta R/R$  after 1000 to 10 000 hours of operation.



# MPR24 MPR34

## COMPOSITION OF THE CATALOGUE NUMBER

a. For tolerances  $\pm 0,05$ ;  $\pm 0,02$  and  $\pm 0,01\%$

2322 14X XXXXX

style \_\_\_\_\_  
MPR24 = 1  
MPR34 = 2

tolerance \_\_\_\_\_  
 $\pm 0,05\% = 6$   
 $\pm 0,02\% = 7$   
 $\pm 0,01\% = 8$

temperature coefficient \_\_\_\_\_  
 $25 \cdot 10^{-6}/K = 0$   
 $15 \cdot 10^{-6}/K = 1$   
 $10 \cdot 10^{-6}/K = 2$   
 $5 \cdot 10^{-6}/K = 3$

Resistance code, fixed by supplier. Any value in the range 24  $\Omega$  to 100 k $\Omega$ . The resistors are marked and packed in cassettes of 20.

resistance range	T.C.	standard packing	$\pm 0,05\%$	$\pm 0,02\%$	$\pm 0,01\%$
			MARKED		
			8th and 9th digit of the catalogue number		
24 $\Omega$	25	20	60xxx	70xxx	80xxx
to	15	20	61xxx	71xxx	81xxx
100 k $\Omega$	10	20	62xxx	72xxx	82xxx
	5	20	63xxx	73xxx	83xxx

b. For tolerances  $\pm 0,5$ ;  $\pm 0,25$  and  $\pm 0,1\%$

2322 14X XXXXX

style \_\_\_\_\_  
MPR24 = 1  
MPR34 = 2

tolerance & packing \_\_\_\_\_  
0,5% 100 = 0  
1000 = 1  
0,25% 100 = 2  
1000 = 3  
0,1% 100 = 4  
1000 = 5

temperature coefficient & coding \_\_\_\_\_  
25  $\cdot 10^{-6}/K$  = 0  
15  $\cdot 10^{-6}/K$  = 1  
10  $\cdot 10^{-6}/K$  = 2  
5  $\cdot 10^{-6}/K$  = 3  
25  $\cdot 10^{-6}/K$  = 4  
15  $\cdot 10^{-6}/K$  = 5  
10  $\cdot 10^{-6}/K$  = 6  
5  $\cdot 10^{-6}/K$  = 7

colour coded }  
marked } = 7

Resistance code, fixed by supplier. Any value in the range 4,99  $\Omega$  to 1 M $\Omega$ , temperature coefficient 25 or 15  $\cdot 10^{-6}/K$ , or any value in the range 4,99  $\Omega$  to 100 k $\Omega$ , temperature coefficient 10 or 5  $\cdot 10^{-6}/K$ .

The resistors are supplied on bandoliers of either 100 or 1000.

resistance range	T.C.	standard packing	$\pm 0,5\%$		$\pm 0,25\%$		$\pm 0,1\%$	
			colour coded	marked	colour coded	marked	colour coded	marked
			8th and 9th digit of the catalogue number					
4,99 $\Omega$	25	100	00xxx	04xxx	20xxx	24xxx	40xxx	44xxx
to		1000	10xxx	14xxx	30xxx	34xxx	50xxx	54xxx
1 M $\Omega$	15	100	01xxx	05xxx	21xxx	25xxx	41xxx	45xxx
		1000	11xxx	15xxx	31xxx	35xxx	51xxx	55xxx
4,99 $\Omega$	10	100	02xxx	06xxx	22xxx	26xxx	42xxx	46xxx
to		1000	12xxx	16xxx	32xxx	36xxx	52xxx	56xxx
100 k $\Omega$	5	100	03xxx	07xxx	23xxx	27xxx	43xxx	47xxx
		1000	13xxx	17xxx	33xxx	37xxx	53xxx	57xxx

## TESTS AND REQUIREMENTS

Essentially all tests are carried out according to the schedule of the CECC publication 40.300 category 55/155/56 (for the 0,5%, 0,25% and 0,1% tolerance classes) and category 25/125/56 (for the 0,05%, 0,02% and 0,01% tolerance classes) along the lines of CECC 40.000, "Recommended basic climatic and mechanical robustness testing procedure for electronic components".

In the following table the tests are listed with reference to the relevant clauses of CECC publication 40.000 and IEC publication 68; a short description is also given on the test procedure and requirements. In some instances deviations from the CECC were necessary for our method of specifying.

Table 2

CECC 40.000 test method	IEC 68 test method	test	procedure	requirements
4.5		Insulation resistance	after 1 min with 500 V d.c.	min. $10^4$ M $\Omega$
4.6		Voltage proof	2 x limiting voltage (a.c.) with a maximum of 750 V (r.m.s.) during 1 min.	no breakdown
4.7		Temperature coefficient	(a) between + 20 °C and + 70 °C (b) between - 55 °C and + 155 °C *	$\leq 25, \leq 15, \leq 10, \leq 5 \cdot 10^{-6}/K$ $\leq 25, 10^{-6}/K$
4.10		Noise	IEC publication 195	$\leq 0,25 \mu V/V$ for $R \leq 100 K\Omega$ $\leq 0,50 \mu V/V$ for $R \leq 100 K\Omega$
4.11		Overload	5 s, $6,25 \times P_{nom}$ or 2 x limiting voltage (whichever the less)	$\Delta R_{max} \leq 0,01\% + 0,01 \Omega$
4.14	Ua Ub Uc	Robustness of terminations Tensile all samples Bending half number of samples Torsion other half number of samples	load 10N, 10 S load 5N, 4 x 90° 3 x 360° in opposite directions	no damage $\Delta R_{max} \leq 0,01\% + 0,01 \Omega$
4.15	T	Soldering	solderability: 2 S 230 °C flux 600 Thermal shock: 3 S 350 °C 6 mm from body	good timing no damage $\Delta R_{max} \leq 0,01\% + 0,01 \Omega$
4.16	Na	Rapid change of temperature	(a) ½ h -25 °C/½ h + 125 °C 5 cycles (b) ½ h -55 °C/½ h + 155 °C 5 cycles *	$\Delta R_{max} \leq 0,01\% + 0,01 \Omega$ $\Delta R_{max} \leq 0,01\% + 0,01 \Omega$
4.17	Eb	Bump	3 x 1500 bumps in three directions, 40 g	no damage $\Delta R_{max} \leq 0,01\% + 0,01 \Omega$

\* (a) and (b) refer to the tolerance groups mentioned on page B60.

**MPR24**  
**MPR34**

CECC 40.000 test method	IEC 68 test method	test	procedure	requirements
4.19	Fc	Vibration	frequency 10 - 500 Hz, displacing 1,5 mm or deceleration 10 g, three directions; total 6 h	no damage $\Delta R_{\max} \leq 0,01\% + 0,01 \Omega$
4.20		Climatic sequence		
4.20.2	B	Dry heat	(a) 16 h; 125 °C (b) 16 h; 155 °C	
4.20.3	D	Damp heat (accel.) 1st cycle	24 h; 95 - 100% R.H.	
4.20.4	Aa	Cold	(a) 2 h; -25 °C (b) 2 h; -55 °C	
4.20.5	M	Low air pressure	1 h; 8,5 kPa; 15 - 35 °C	
4.20.6	D	Damp heat (accel.) remaining cycles	5 days; 95 - 100% R.H.	$R_{\text{ins}}$ min. 100 M $\Omega$ $\Delta R_{\max} \leq 0,05\% + 0,01 \Omega$
4.21	Ca	Damp heat, Steady state (long term exposure)	56 days 40 °C; 90 - 95% R.H. dissipation $\leq 1,25$ mW	$R_{\text{ins}}$ min. 100 M $\Delta R_{\max} \leq 0,05\% + 0,01 \Omega$
4.24		Endurance 1½ h on/½ h off	2000 h 70 °C dissipation $P_{\text{nom}}$	$R_{\text{ins}}$ min. 100 M $\Omega$ $\Delta R_{\max} < 0,05\% + 0,01 \Omega$

\* (a) and (b) refer to the tolerance groups mentioned on page B60.

**STANDARD PACKAGING**

100 resistors on bandolier in a cardboard box; 1000 resistors on bandolier in ammopack, or 20 resistors in cassette, including list with individual measuring details.

**Configuration of bandolier**

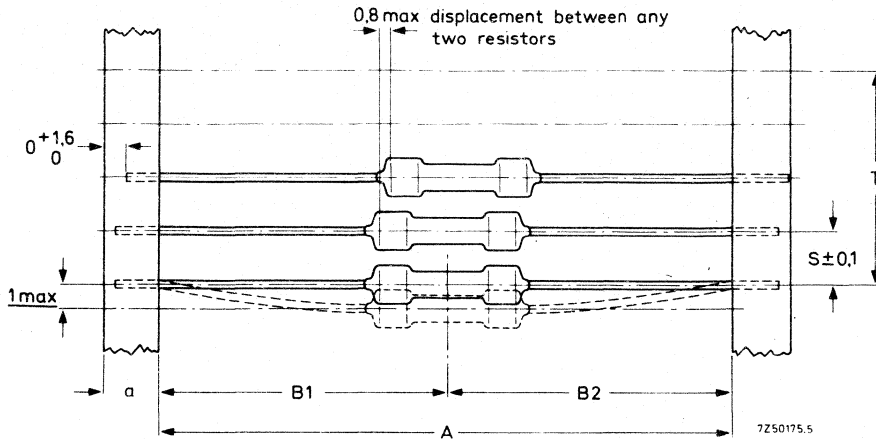

Fig. 4.

type	a ± 0,5	A ± 1,5	B1 - B2 ± max.	S spacing	T max. deviation of spacing
MPR24	6	63,5	1,2	5	} 1 mm per 10 spacings } 0,5 mm per 5 spacings
MPR34	6	63,5	1,2	5	





## HIGH-OHMIC/HIGH-VOLTAGE RESISTORS

### QUICK REFERENCE DATA

Resistance range	220 k $\Omega$ to 15 M $\Omega$ , E24/E96 series 220 k $\Omega$ to 10 M $\Omega$ , E24 series 12 M $\Omega$ to 22 M $\Omega$ , E12 series
Resistance tolerance	$\pm 1\%$ (E24/E96), $\pm 5\%$ (E24), $\pm 10\%$ (E12)
Max. permissible body temperature (hot spot)	155 $^{\circ}\text{C}$
Temperature coefficient	$\pm 200 \cdot 10^{-6}/\text{K}$
Rated dissipation at $T_{\text{amb}} = 70^{\circ}\text{C}$	0,25 W
Limiting voltage	1600 V (d.c.) or 1150 V (r.m.s.)
Dielectric withstanding voltage of the insulation for 1 minute	min. 700 V (r.m.s.)
Basic specification	IEC 115, type 1B
Climatic category (IEC 68)	55/155/56
Stability after:	
1000 h max. load	$\Delta R/R$ max. 3%
accelerated damp heat test (6 days)	$\Delta R/R$ max. 3%
long-term damp heat test (56 days)	$\Delta R/R$ max. 3%
Noise	max. 5 $\mu\text{V}/\text{V}$

### APPLICATION

These resistors are for applications in which high resistance, high stability and reliability are required at high voltages. The resistors meet the safety requirements of IEC 65.

### DESCRIPTION

A metal-glazed film is deposited on a high grade ceramic body; tinned electrolytic copper connecting wires are welded to the end caps. The resistors are coated with a light-blue insulating lacquer which also provides protection against environmental effects.

### MECHANICAL DATA

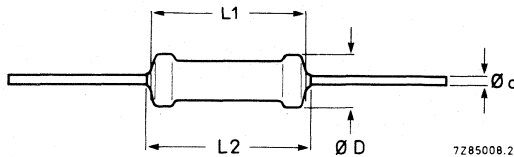

Fig. 1 Axial leads.

Table 1

type	$D_{\text{max}}$	$L_1 \text{ max}$	$L_2 \text{ max}$	d
VR25	2,5	6,5	7,5	0,6

The length of the body is measured by inserting the leads into holes of two identical gauge plates and moving these plates parallel to each other until the resistor body is clamped without deformation (IEC publication 294). For leads of 0,6 mm diameter, the diameter of the holes in the gauge plates is 1,0 mm.

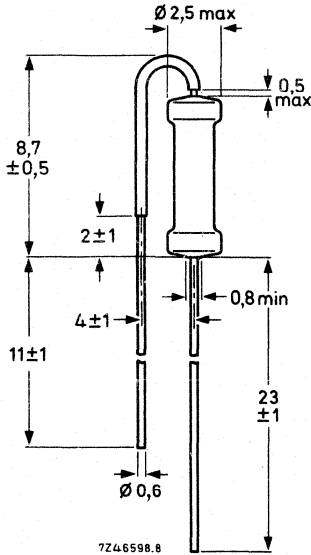

Fig. 2 "Stand-up" type VR25A, for vertical mounting. The bent lead is partially covered with an insulating lacquer with a breakdown voltage of at least 50 V (d.c.).

**Mass** 23 g per 100 resistors

**Mounting**

The resistors are suitable for processing on automatic insertion equipment and cutting and bending machines. The minimum pitch for the type with axial leads is 5 e (12,7 mm). The "stand-up" type, VR25A, can be inserted into holes with a pitch of 1 e.

**Marking**

The nominal resistance and the tolerance are marked on these resistors by four or five coloured bands according to IEC publication 62 "Colour code for fixed resistors". See General Section.

Yellow and grey are used instead of gold and silver because metal particles in the lacquer could affect high-voltage properties.

**ELECTRICAL DATA****Standard values of rated resistance and tolerance**

Standard values of rated resistance (nominal resistance) are taken from the

E12 series within the range 12 M $\Omega$  to 22 M $\Omega$  for R  $\pm$  10%,

E24 series within the range 220 k $\Omega$  to 10 M $\Omega$  for R  $\pm$  5% and

E24/E96 series within the range 220 k $\Omega$  to 15 M $\Omega$  for R  $\pm$  1%

See the table "Standard series of values in a decade" at the back of the book.

The limiting voltage for resistor element and insulation is the maximum voltage that may be applied continuously to the resistor element or the insulation, see IEC publications 115-1 and 115-2. This voltage is 1600 V (d.c.) or 1150 V (r.m.s.).

Table 2

type	packing	quantity	resistance range	tolerance $\pm$ %	series	catalogue number 2322 followed by:
VR25	ammopack	1000	220 k $\Omega$ to 15 M $\Omega$	1	E24/E96	241 8...
			220 k $\Omega$ to 10 M $\Omega$	5	E24	241 13...
			12 M $\Omega$ to 22 M $\Omega$	10	E12	241 12...
	on reel	5000	220 k $\Omega$ to 10 M $\Omega$	5	E24	241 53...
			12 M $\Omega$ to 22 M $\Omega$	10	E12	241 52...
			220 k $\Omega$ to 10 M $\Omega$	5	E24	241 23...
12 M $\Omega$ to 22 M $\Omega$	10	E12	241 22...			
				VR25	ammopack	2000
26 mm bandolier	2000	12 M $\Omega$ to 22 M $\Omega$	10	E12		241 42...
VR25A "stand-up"	in box (loose)	1000	220 k $\Omega$ to 10 M $\Omega$	5	E24	241 33...
			12 M $\Omega$ to 22 M $\Omega$	10	E12	241 32...
VR25AS radial taped	ammopack	2000	220 k $\Omega$ to 10 M $\Omega$	5	E24	243 13...
			12 M $\Omega$ to 22 M $\Omega$	10	E12	243 12...
	on reel	4000	220 k $\Omega$ to 10 M $\Omega$	5	E24	243 33...
			12 M $\Omega$ to 22 M $\Omega$	10	E12	243 32...

**COMPOSITION OF THE CATALOGUE NUMBER**

The catalogue number in the above table is completed by inserting the resistance code: the first two figures (for 1% tolerance first three figures) of the resistance, followed by:

4 for R = 280 to 910 k $\Omega$

5 for R = 1 to 9,1 M $\Omega$

6 for R > 10 M $\Omega$

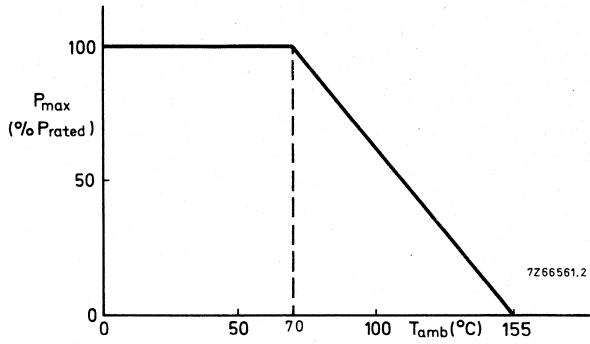

Fig. 3 Maximum dissipation ( $P_{max}$ ) as a function of the ambient temperature ( $T_{amb}$ ).

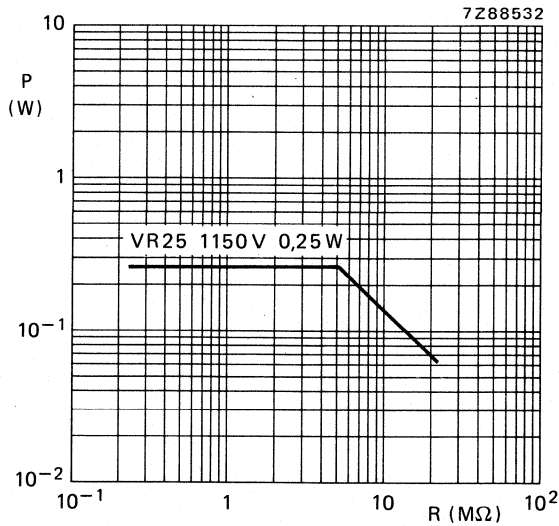

Fig. 4 Maximum permissible dissipation at  $T_{amb} = 70$  °C as a function of the resistance.

## TESTS AND REQUIREMENTS

Essentially all tests are carried out according to the schedule of IEC publication 115-1, category 55/155/56 (rated temperature range  $-55$  to  $+155$  °C; damp heat, long term, 56 days) and along the lines of IEC publication 68, "Recommended basic climatic and mechanical robustness testing procedure for electronic components". In the following table the tests are listed with reference to the relevant clauses of IEC publications 115-1 and 68; a short description is also given of the test procedure and requirements. In some instances deviations from the IEC recommendation were necessary for our method of specifying.

Table 4

IEC 115-1 clause	IEC 68 test method	test	procedure	requirements
18	Ua	Robustness of terminations Tensile all samples	load 10N; 10 s	} number of failures: < 10 ppm  no damage $\Delta R$ max. 0,5% + 0,05 $\Omega$
	Ub	Bending half number of samples	load 5N; 4 x 90°	
	Uc	Torsion other half number of samples	3 x 360° in opposite directions	
19	T	Soldering	solderability: 2 s 230 °C, flux 600 thermal shock: 3 s 350 °C, 6 mm from body	good tinning, no damage $\Delta R$ max. 0,5% + 0,05 $\Omega$
20	Na	Rapid change of temperature	$\frac{1}{2}$ h $-55$ °C/ $\frac{1}{2}$ h $+155$ °C, 5 cycles	$\Delta R$ max. 0,5% + 0,05 $\Omega$
22	Fc	Vibration	frequency 10-500 Hz, displacement 1,5 mm or acceleration 10g, three directions; total 6 h (3 x 2 h)	no damage $\Delta R$ max. 0,5% + 0,05 $\Omega$
21	Eb	Bump	3 x 1500 bumps in three directions, 40g	no damage $\Delta R$ max. 0,5% + 0,05 $\Omega$

IEC 115-1 clause	IEC 68 test method	test	procedure	requirements
23		Climatic sequence		
23.2	Ba	Dry heat	16 h, 155 °C	
23.3	D	Damp heat (accel) 1st cycle	24 h; 55 °C; 95-100% R.H.	
23.4	Aa	Cold	2 h; -55 °C	
23.5	M	Low air pressure	2 h; 8,5 kPa; 15-35 °C	
23.6	D	Damp heat (accel) re-remaining cycles	5 days; 55 °C; 95-100% R.H.	$R_{ins}$ min. 1000 M $\Omega$ $\Delta R$ max. 3%
24.2	Ca	Damp heat steady state	56 days; 40 °C; 90-95% R.H. dissipation $\leq 0,01 P_n$ limiting voltage 16 V (d.c.)	$R_{ins}$ min. 1000 M $\Omega$ $\Delta R$ max. 3%
26.2	—	Endurance	1000 hours; 70 °C nominal dissipation or $V_{max}$	$\Delta R$ max. 3%
11	—	Temperature coefficient	between -55 °C and + 155 °C	$\pm 200 \cdot 10^{-6}/K$
10	—	Voltage proof on insulation	700 V (r.m.s.), 1 minute	no breakdown
14	—	Noise	IEC publication 195	max. 5 $\mu V/V$
9	—	Insulation resistance		min. 10 <sup>4</sup> M $\Omega$
—	—	Short time overload	Room temperature, dissipation 6,25 $P_n$ (voltage not more than 2 x limiting voltage), 10 cycles 5 s on, 45 s off	$\Delta R$ max. 0,5% + 0,05 $\Omega$

PACKAGING

Resistors with axial leads are supplied on bandolier in ammpack or on reel; those with radial leads are either loose in a cardboard box or — with bent leads — on a bandolier in ammpack.

type	quantity per box		
	bandolier ammpack	bulk loose	bandolier on reel
VR25	1000/2000/5000	—	5000
VR25A	—	1000	—
VR25AS	2000	—	4000

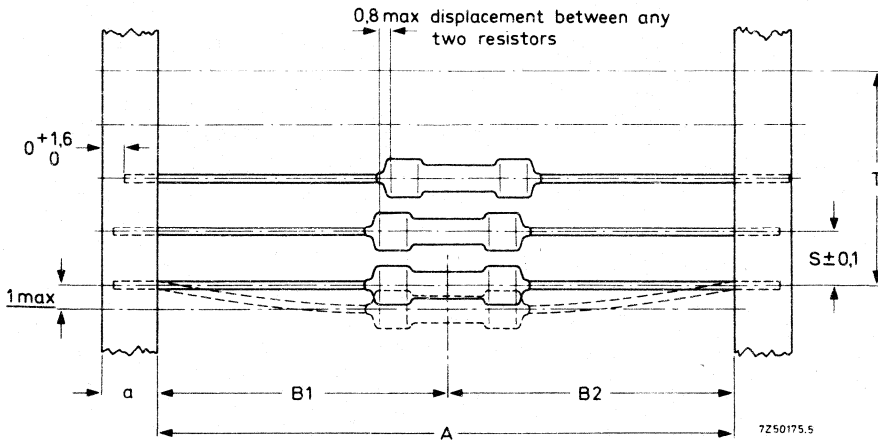

Fig. 5 Bandolier for VR25, axial types.

type	a ± 0,5	A	B1 - B2 ± max.	S (spacing)	T (max. deviation of spacing)
VR25	6	52,5 ± 1,5	1,2	5	} 1 mm per 10 spacings } 0,5 mm per 5 spacings
VR25	6	26 + 1,5 - 0	1,0	5	

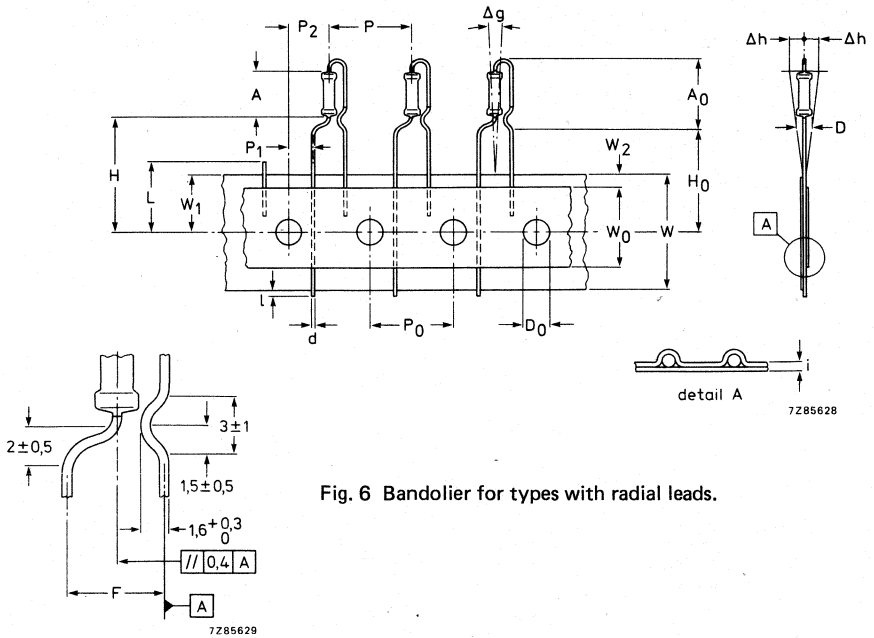

Fig. 6 Bandolier for types with radial leads.

Body diameter	D	max.	2,50
Body length	A	max.	7,00
Mounting height	A <sub>0</sub>	max.	12,50
Lead wire diameter	d		0,60 ± 0,06
Pitch of components	P		12,7 ± 1,0
Feed hole pitch	P <sub>0</sub>		12,7 ± 0,3
Maximum deviation of spacing	T		1,0 per 20 spacings
Feed hole centre to lead	P <sub>1</sub>		3,85 ± 0,7
Feed hole centre to body	P <sub>2</sub>		6,35 ± 1,0
Lead to lead distance	F		5,0 + 0,8 - 0,2
Component alignment	Δh		0 ± 2 mm
Component alignment	Δg		0 ± 3°
Tape width	W		18,0 + 1 - 0,8
Hold down tape width	W <sub>0</sub>		6,5 or 12,5
Hole position	W <sub>1</sub>		9,0 ± 0,5
Hold down tape position	W <sub>2</sub>		2 + 0 - 1,5
Distance component to tape centre	H		19,0 ± 1
Lead wire clinch height	H <sub>0</sub>		16,0 ± 0,5
Lead wire protrusion	ℓ	max.	0
Feed hole diameter	D <sub>0</sub>		4,0 ± 0,3
Total tape thickness	i	max.	0,9
Length of cropped lead	L	max.	11,0

Extraction force for components in the tape plane, vertically to the direction of unreeling: ≥ 5N.



Reel dimensions

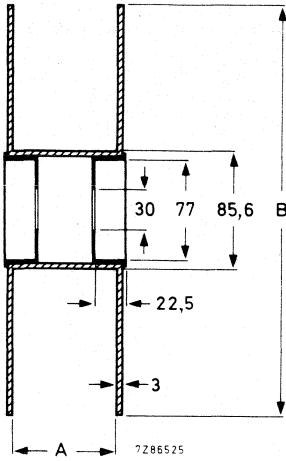

type	quantity	A	B
VR25	5000	75	305
VR25AS	4000	40	356

Length of leader at beginning and end  
(bandolier without resistors): 300 mm





## HIGH-OHMIC/HIGH-VOLTAGE RESISTORS

### QUICK REFERENCE DATA

Type		VR37	VR68
Resistance range	E24 series E24/E96 series	220 k $\Omega$ to 33 M $\Omega$ 220 k $\Omega$ to 33 M $\Omega$	100 k $\Omega$ to 68 M $\Omega$ 100 k $\Omega$ to 68 M $\Omega$
Resistance tolerance	E24 series E24/E96 series	$\pm 5\%$ $\pm 1\%$	$\pm 5\%$ $\pm 1\%$
Max. permissible body temperature (hot spot)		155 $^{\circ}\text{C}$	155 $^{\circ}\text{C}$
Temperature coefficient		$\pm 200 \cdot 10^{-6}/\text{K}$	$\pm 200 \cdot 10^{-6}/\text{K}$
Rated dissipation at $T_{\text{amb}} = 70 \text{ }^{\circ}\text{C}$		0,5 W	1,0 W
Limiting voltage			
d.c.		3,5 kV	10 kV
r.m.s.		2,5 kV	7 kV
Dielectric withstanding voltage of the insulation for 1 minute	min.	700 V	700 V
Basic specification		IEC 115-1B	IEC 115-1B
Climatic category (IEC 68)		55/155/56	55/155/56
Stability after:			
1000 h max. load	$\Delta R/R$ max.	0,5%	1%
6 days damp-heat test	$\Delta R/R$ max.	0,5%	1%
56 days damp-heat test	$\Delta R/R$ max.	0,5%	0,5%
Noise	max.	0,5 $\mu\text{V}/\text{V}$	0,5 $\mu\text{V}/\text{V}$

### APPLICATION

Where high resistance, high stability and high reliability at high voltage are required. The resistors meet the safety requirements of IEC 65, 4th edition; NFC 92.130; BS415; VDE 0860.

### DESCRIPTION

A metal-glazed film is deposited on a high grade ceramic body; tinned electrolytic copper wires are welded to the end caps. The resistors are coated with a light blue insulating lacquer which also provides protection against environmental effects.

### MECHANICAL DATA

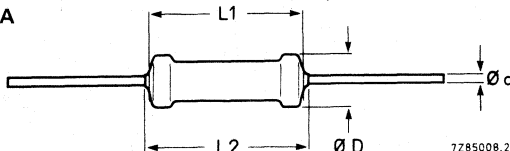

Fig. 1 Axial leads.

Table 1

type	$D_{\text{max}}$	$L_1 \text{ max}$	$L_2 \text{ max}$	d
VR37	3,7	9,0	10,0	0,7
VR68	6,8	18,0	19,0	0,8

# VR37 VR68

The length of the body is measured by inserting the leads into holes of two identical gauge plates and moving those plates parallel to each other until the resistor body is clamped without deformation (IEC publication 294). For leads of 0,7 mm diameter, the diameter of the holes in the gauge plates is 1,0 mm; for leads of 0,8 mm diameter, the holes are 1,2 mm.

Mass (per 100) VR37: 42g; VR68: 148g

## Mounting

The resistors are suitable for processing on automatic insertion equipment and cutting and bending machines.

## Marking

The nominal resistance and the tolerance are marked on these resistors by four (E24 series) or five (E96 + E24) coloured bands according to IEC publication 62 "Colour code for fixed resistors". See General Section.

Yellow and grey are used instead of gold and silver, because metal particles in the lacquer could affect high-voltage properties.

## ELECTRICAL DATA

### Standard values of rated resistance and tolerance

Standard values of rated resistance (nominal resistance) are taken from the E24/E96 series (tolerance  $\pm 1\%$ ) and E24 series (tolerance  $\pm 5\%$ ) within the range 220 k $\Omega$  to 37 M $\Omega$  for type VR37 and 100 k $\Omega$  to 68 M $\Omega$  for type VR68. Values up to 220 M $\Omega$  are available on request. See the table "Standard series of values in a decade" at the back of the book.

The limiting voltage for resistor element and insulation is the maximum voltage that may be supplied continuously to the resistor element or the insulation, see IEC publications 115-1 and 115-2. This voltage is 3500 V (d.c.) or 2500 V (r.m.s.) for type VR37 and 10 kV (d.c.) or 7 kV (r.m.s.) for type VR68.

### COMPOSITION OF THE CATALOGUE NUMBER

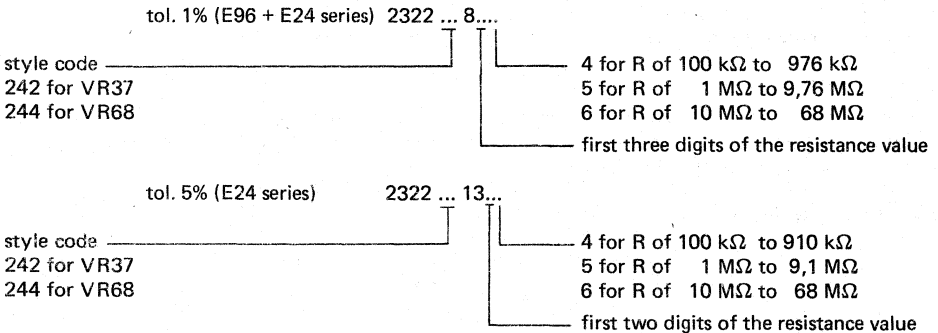

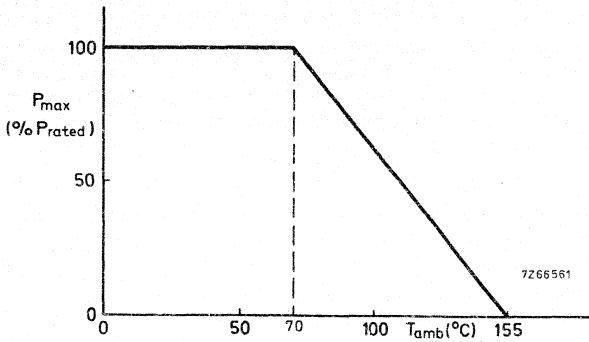

Fig. 2 Maximum dissipation ( $P_{max}$ ) as a function of the ambient temperature ( $T_{amb}$ ).

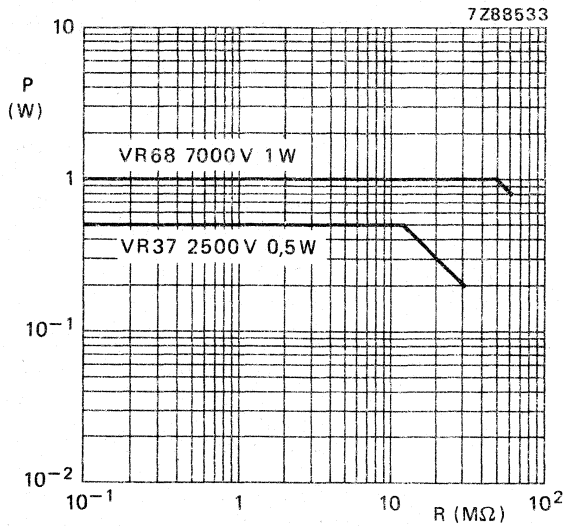

Fig. 3 Power versus resistance value of high-voltage resistors at  $T_{amb} = 70^\circ\text{C}$ .

**TESTS AND REQUIREMENTS**

Essentially all tests are carried out according to the schedule of IEC publication 115-1, category 55/155/56 (rated temperature range -55 to + 155 °C; damp heat, long term, 56 days) and along the lines of IEC publication 68, "Recommended basic climatic and mechanical robustness testing procedure for electronic components". In the following table the tests are listed with reference to the relevant clauses of IEC publications 115-1 and 68; a short description is also given of the test procedure and requirements. In some instances deviations from the IEC recommendation were necessary for our method of specifying.

Table 4

IEC 115-1 clause	IEC 68 test method	test	procedure	requirements
18	Ua Ub Uc	Robustness of terminations Tensile all samples Bending half number of samples Torsion other half number of samples	load 10N; 10 s  load 5N; 4 x 90°  3 x 360° in opposite directions	number of failures: < 10 ppm  no damage ΔR max. 0,5% + 0,05 Ω
19	T	Soldering	solderability: 2 s 230 °C, flux 600 thermal shock: 3 s 350 °C, 6 mm from body	good tinning, no damage ΔR max. 0,5% + 0,05 Ω
20	Na	Rapid change of temperature	½ h -55 °C/½ h + 155 °C, 5 cycles	ΔR max. 0,5% + 0,05 Ω
22	Fc	Vibration	frequency 10-500 Hz, displacement 1,5 mm or acceleration 10g, three directions; total 6 h (3 x 2 h)	no damage ΔR max. 0,5% + 0,05 Ω
21	Eb	Bump	3 x 1500 bumps in three directions, 40g	no damage ΔR max. 0,5% + 0,05 Ω

IEC 115-1 clause	IEC 68 test method	test	procedure	requirements
23		Climatic sequence		
23.2	Ba	Dry heat	16 h, 155 °C	
23.3	D	Damp heat (accel) 1st cycle	24 h; 55 °C; 95-100% R.H.	
23.4	Aa	Cold	2 h; -55 °C	
23.5	M	Low air pressure	2 h; 8,5 kPa; 15-35 °C	
23.6	D	Damp heat (accel) re-maining cycles	5 days; 55 °C; 95-100% R.H.	$R_{ins}$ min. 1000 M $\Omega$ $\Delta R$ max. 1,5%
24.2	Ca	Damp heat steady state	56 days; 40 °C; 90-95% R.H. dissipation $\leq 0,01 P_n$ limiting voltage 16 V (d.c.)	$R_{ins}$ min. 1000 M $\Omega$ $\Delta R$ max. 1,5%
26.2	—	Endurance	1000 hours; 70 °C nominal dissipation or $V_{max}$	$\Delta R$ max. 1,5%
11	—	Temperature coefficient	between -55 °C and + 155 °C	$\pm 200 \cdot 10^{-6}/K$
10	—	Voltage proof on insulation	700 V (r.m.s.), 1 minute	no breakdown
14	—	Noise	IEC publication 195	max. 2,5 $\mu V/V$
9	—	Insulation resistance		min. 10 <sup>4</sup> M $\Omega$



STANDARD PACKAGING

The resistors are supplied on bandolier, VR37 1000 items per box, VR68 500 items per box (ammopack).

Configuration of bandolier

Dimensions in mm

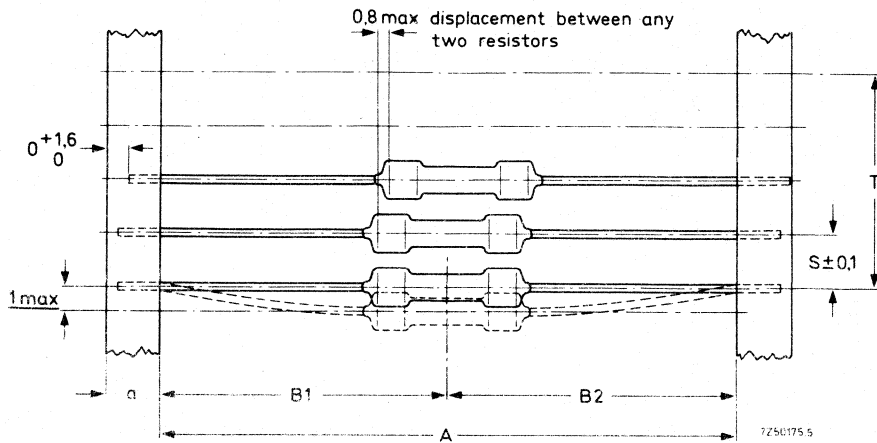

Fig. 4.

type	a $\pm 0,5$	A $\pm 1,5$	B1 - B2 $\pm max.$	S (spacing)	T (max. deviation of spacing)
VR37	6	52,4	1,2	5	} 1 mm per 10 spacings } 0,5 mm per 5 spacings
VR68	5	66,7	1,2	10	



## POWER METAL FILM RESISTORS

### QUICK REFERENCE DATA

Resistance range	PR37	2,2 $\Omega$ to 27 k $\Omega$ , E24 series *
	PR52	2,2 $\Omega$ to 51 k $\Omega$ , E24 series *
Resistance tolerance		$\pm 5\%$
Max. body temperature (hot spot)		300 $^{\circ}\text{C}$
Rated dissipation at $T_{\text{amb}} = 70^{\circ}\text{C}$	PR37	1,6 W
	PR52	2,5 W
Basic specification		MIL-R-11804/2, char. G
Climatic category (IEC 68)		55/200/56
Stability after		requirement
1000 h max. load		$\Delta R \leq 5\%$
climatic tests		$\Delta R \leq 3\%$
soldering		$\Delta R \leq 1\%$
short time overload		$\Delta R \leq 2\%$
		typical value
		$\Delta R$ 2,5%
		$\Delta R$ 0,5%
		$\Delta R$ 0,1%
		$\Delta R$ 0,2%

### DESCRIPTION

The resistive element consists of a chromium-nickel film deposited on a ceramic body and adjusted to value by spiralling. Contact caps with tinned copper or tinned copper-clad iron connecting wires are force-fitted onto the ends of the ceramic body.

The resistor has a red non-inflammable coating of a protective silicon lacquer which can withstand 500 V (r.m.s.) and is resistant against most of the commonly used cleaning solvents.

### COMPOSITION OF THE CATALOGUE NUMBER

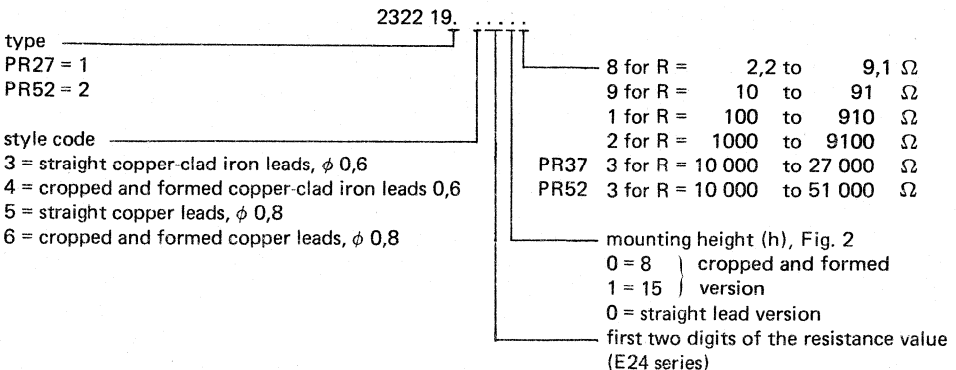

\* Values 1 to 2  $\Omega$  can be delivered on request.

MECHANICAL DATA

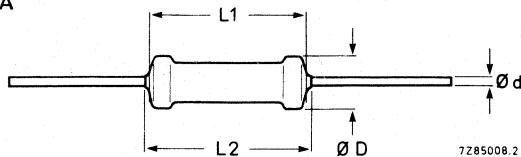

Fig. 1 Version with straight leads, see Table 1.

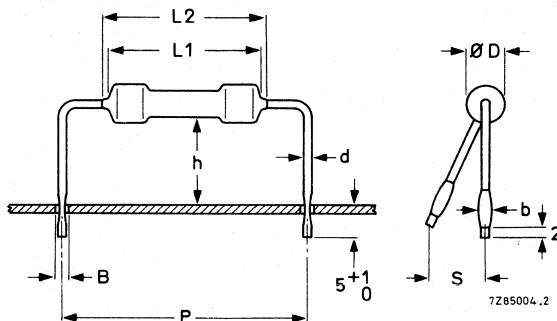

Fig. 2 Version with cropped and formed leads.

Table 1

type	leads	D <sub>max</sub>	L <sub>1max</sub>	L <sub>2max</sub>	d	b +0,1	h +2	S <sub>max</sub>	P ± 3	B φ <sub>max</sub>
PR37	copper-clad iron	3,9	10	11	0,6	1,1	8	2	17,8	1,0
		3,9	10	11	0,6	1,1	15	3	17,8	1,0
	copper	3,9	10	11	0,8	1,3	8	2	17,8	1,2
		3,9	10	11	0,8	1,3	15	3	17,8	1,2
PR52	copper-clad iron	5,2	16,7	17,9	0,6	1,1	8	2	25,4	1
		5,2	16,7	17,9	0,6	1,1	15	3	25,4	1
	copper	5,2	16,7	17,9	0,8	1,3	8	2	25,4	1,2
		5,2	16,7	17,9	0,8	1,3	15	3	25,4	1,2

Mass (per 100) PR37: 40 g; PR52: 92 g.

Mounting

The resistors must be mounted stress free so as to allow thermal expansion over the wide permissible temperature range. The mounting pitch of version with cropped and formed leads is 7 e for PR37 and 10 e for PR52.

Marking

Each resistor is marked with:  
 -- resistance value (R for Ω, K for kΩ)  
 -- tolerance on resistance in %.

Example: 27 R ± 5%

**ELECTRICAL DATA**

**Standard values of rated resistance and tolerance**

Standard values of rated resistance (nominal resistance) are taken from the E24 series within the range 2,2 Ω to 27 kΩ (type PR37) and 2,2 Ω to 51 kΩ (type PR52). \* E24 series of values is given in the table "Standard series of values in a decade" at the back of the handbook. The tolerance on the rated resistance is ± 5%.

Temperature coefficient

$R \geq 10 \Omega$

max.  $\pm 250 \cdot 10^{-6} / K$

$R < 10 \Omega$

max.  $\pm 350 \cdot 10^{-6} / K$

Maximum body temperature (hot spot)

300 °C

Rated dissipation at  $T_{amb} = 70 \text{ °C}$

PR37 1,6 W

PR52 2,5 W

Dielectric withstanding r.m.s. voltage of the insulation for 1 min

min. 500 V

Basic specification

MIL-R-11804/E, char. G

Climatic category (IEC 68)

55/200/56

Temperature rise ( $\Delta T$ ) of the resistor body as a function of dissipation

see Figs 3, 4, 7, 8

Lead length (l) as a function of dissipation with temperature rise at end of lead (soldering place) as parameter

see Figs 5, 6, 9, 10

**TESTS AND REQUIREMENTS (in accordance with MIL-R-11804E or IEC 115-2)**

MIL test			requirement	
R-11804E paragraph	STD-202D method	procedure	MIL-R-11804E paragraph	
4. 6. 1		Visual and mechanical examination	3. 1; 3. 3 to 3. 4. 3 3. 21 to 3. 22. 1	
4. 6. 2	303	D.C. resistance		within tolerance
4. 6. 3		Temperature	3. 7	$\Delta R \leq 2\%$
4. 6. 6		Hot spot	3. 10	see Fig. 2, 4, 7, 8
4. 6. 7		Thermal shock	3. 11	$\Delta R \leq 2\%$ , no damage
4. 6. 8		Momentary overload	3. 12	$\Delta R \leq 2\%$ , no damage
4. 6. 9	106	Moisture resistance	3. 13	$\Delta R \leq 3\%$
4. 6. 11	211	Terminal strength	3. 15	$\Delta R \leq 1\%$ , no damage
4. 6. 12	208	Lead solderability	3. 16	95% covered
4. 6. 13	304	Temperature coefficient		$R \geq 10 \Omega: \leq 250 \cdot 10^{-6} / K$ $R < 10 \Omega: \leq 350 \cdot 10^{-6} / K$
4. 6. 14	108	Load life	3. 17	$\Delta R \leq 5\%$ , no damage
4. 6. 15	205	Shock	3. 19	$\Delta R \leq 0,5\% + 0,05 \Omega$
4. 6. 16	204	Vibration (high frequency)	3. 20	$\Delta R \leq 0,5\% + 0,05 \Omega$ no damage
IEC 115	IEC 68	Damp heat		$\Delta R \leq 3\%$

\* Resistors of 1 to 2 Ω can be supplied on request.

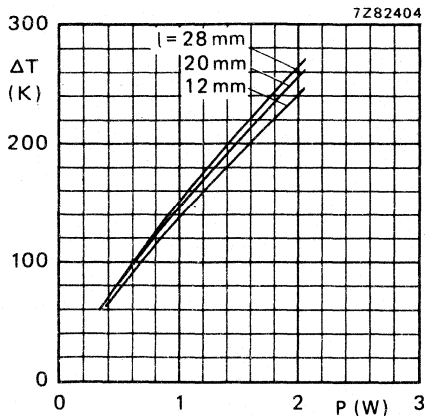

Fig. 3 PR37. Hot-spot temperature rise ( $\Delta T$ ) versus dissipated power ( $P$ ) at different lead lengths ( $l$ ), copper-clad iron leads  $\phi = 0,6$  mm.

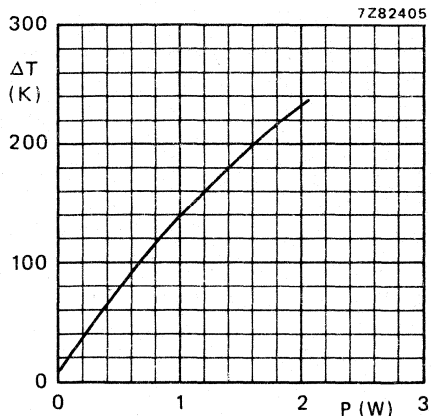

Fig. 4 PR37. Hot-spot temperature rise ( $\Delta T$ ) versus dissipated power ( $P$ ), copper leads  $\phi = 0,8$  mm.

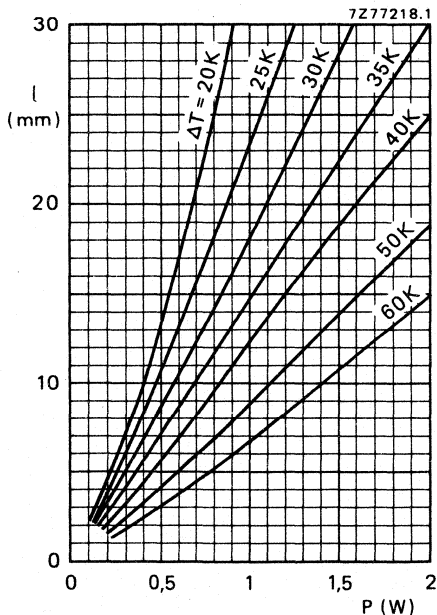

Fig. 5 PR37. Lead length  $l$  versus dissipated power with  $\Delta T$  as a parameter, copper-clad iron leads  $\phi = 0,6$  mm.

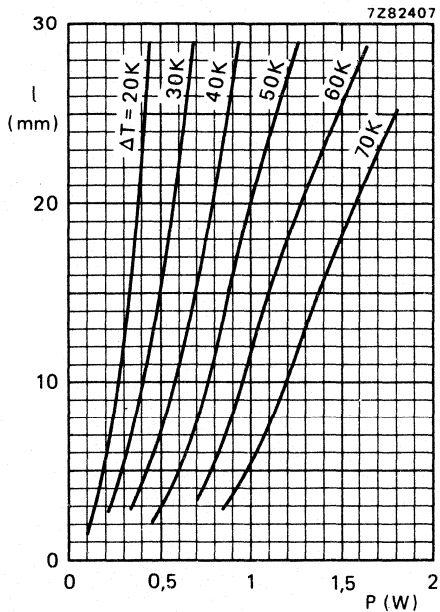

Fig. 6 PR37. Lead length  $l$  versus dissipated power with  $\Delta T$  as a parameter, copper leads  $\phi = 0,8$  mm.

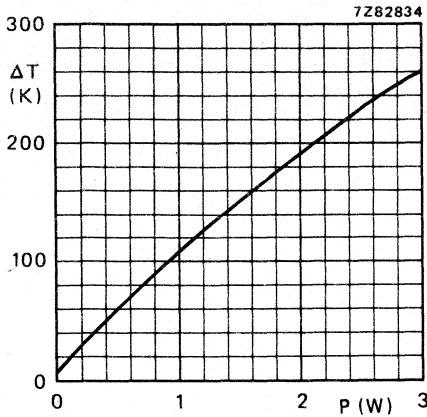

Fig. 7 PR52. Hot-spot temperature rise ( $\Delta T$ ) versus dissipated power ( $P$ ) copper-clad iron leads  $\phi = 0,6$  mm.

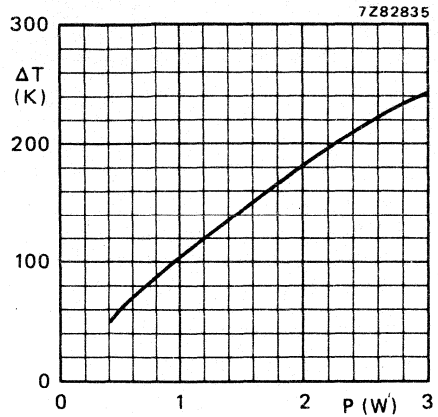

Fig. 8 PR52. Hot-spot temperature rise ( $\Delta T$ ) versus dissipated power ( $P$ ), copper leads  $\phi = 0,8$  mm.

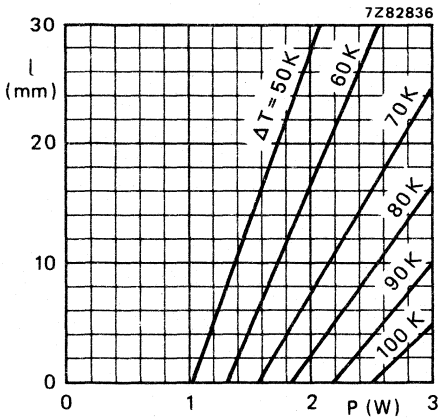

Fig. 9 PR52. Lead length  $l$  versus dissipated power with  $\Delta T$  as a parameter, copper-clad iron leads  $\phi = 0,6$  mm.

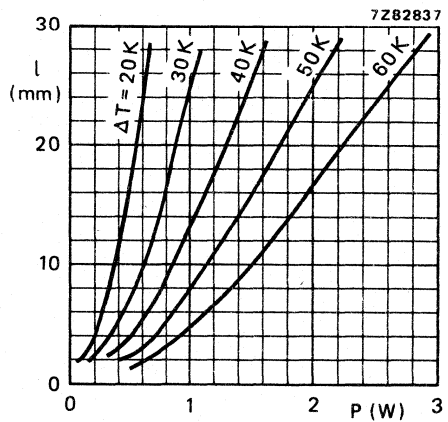

Fig. 10 PR52. Lead length  $l$  versus dissipated power with  $\Delta T$  as a parameter, copper leads  $\phi = 0,8$  mm.



**PR37  
PR52**

**STANDARD PACKAGING**

type and style	quantity per box	
	on bandolier ammopack	bulk loose
PR37, straight leads	1000	
PR52, straight leads	500	
PR37 cropped and formed leads, h = 8 mm		1000
h = 15 mm		500
PR52 cropped and formed leads, h = 8 mm		500
h = 15 mm		250

**Configuration of bandolier**

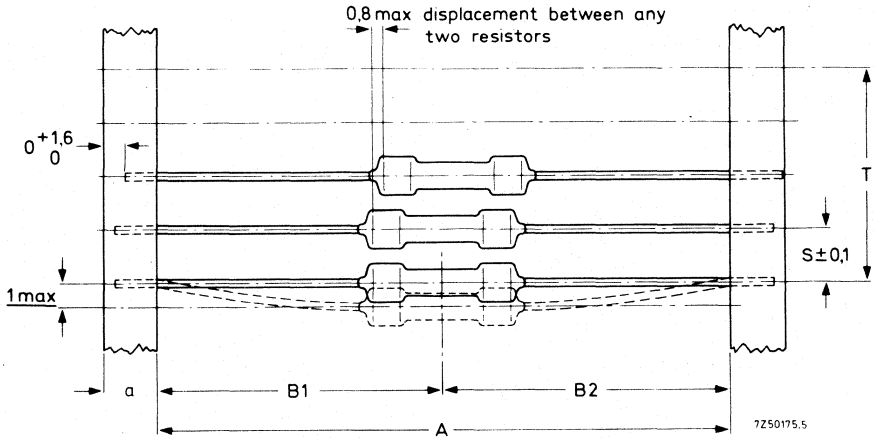

Fig. 11.

type	a ± 0,5	A ± 1,5	B1 - B2 ± max.	S (spacing)	T
					(max. deviation of spacing)
PR37	6	73	1,2	5	} 1 mm per 10 spacings } 0,5 mm per 5 spacings
PR52	6	80	1,2	10	

## CEMENTED WIREWOUND RESISTORS

### QUICK REFERENCE DATA

Resistance range	0,1 $\Omega$ to 33 k $\Omega$ , E24 series
Resistance tolerance	$\pm 5\%$ or $\pm 10\%$
Max. permissible body temperature (hot spot)	350 $^{\circ}\text{C}$
Rated dissipation at $T_{\text{amb}} = 40\text{ }^{\circ}\text{C}$	AC04: 4 W, AC10 = 10 W AC05: 5 W, AC15 = 15 W AC07: 7 W, AC20 = 20 W
Basic specification	IEC 266
Climatic category (IEC 68)	40/200/56
Stability after	
load	$\Delta R/R$ max. 5%
climatic tests	$\Delta R/R$ max. 5%
short time overload	$\Delta R/R$ max. 2%

### APPLICATION

These resistors have been designed to dissipate high powers in a small volume.

### DESCRIPTION

The resistor element is wound in a single layer on a ceramic rod. Metal caps are pressed over the ends of the rod. The ends of the resistance wire and the leads are connected to the caps by welding. Tinned copper-clad iron leads with poor heat conductivity are employed permitting the use of relatively short leads to obtain stable mounting. The resistor is coated with a green silicon cement which is non-inflammable and cannot drip even at high overloads, and is resistant to most commonly used cleaning solvents, according to MIL-STD-202E, method 215 and IEC 68-2-45 test XA.

### MECHANICAL DATA

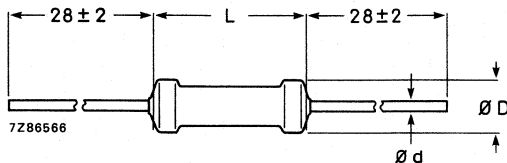

Fig. 1.

Table 1

type	$D_{\text{max}}$	$L_{\text{max}}$	d
AC04	6	19	0,6
AC05	8	19	0,8
AC07	8	27	0,8
AC10	8	44	0,8
AC15	10	51	0,8
AC20	10	67	0,8

Note: The lead length ( $28 \pm 2$  mm) only applies to untaped resistors, i.e. types AC10, AC15 and AC20.

The length of the body is measured by inserting the leads into the holes of two identical gauge plates and moving these plates parallel to each other until the resistor body is clamped without deformation (IEC publication 294). For leads of 0,6 mm diameter, the diameter of the holes is 1,0 mm; for leads of 0,8 mm diameter the holes are 1,2 mm.

**Mass (per 100)**

AC04	100 g
AC05	175 g
AC07	225 g
AC10	530 g
AC15	840 g
AC20	1090 g

**Mounting**

The resistors AC04, AC05 and AC07 are suitable for processing on cutting and bending machines. Care should be taken that the temperature rise of the resistor body does not affect nearby components or materials by conducted or convected heat. The temperature rise of the resistor body and of leads of different lengths is given as a function of the dissipation in Figs 2 and 3.

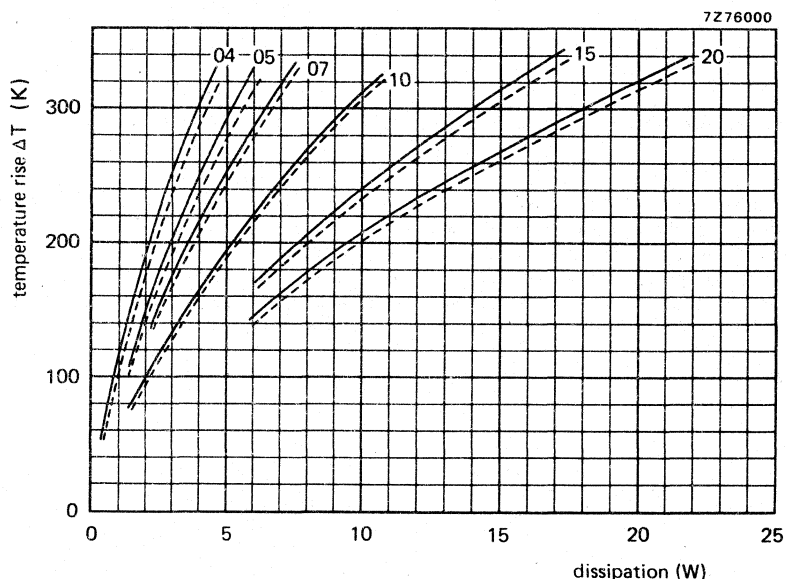

Fig. 2 Temperature rise of the resistor body as a function of the dissipation.  
 — for lead length of 25 mm  
 - - - for lead length of 10 mm



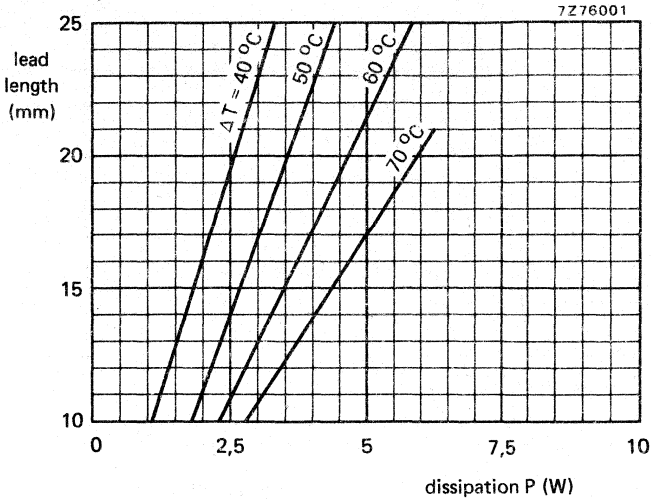

Fig. 3a Lead length as a function of the dissipation with the temperature rise at the end of the lead (soldering spot) as parameter, for style AC04.

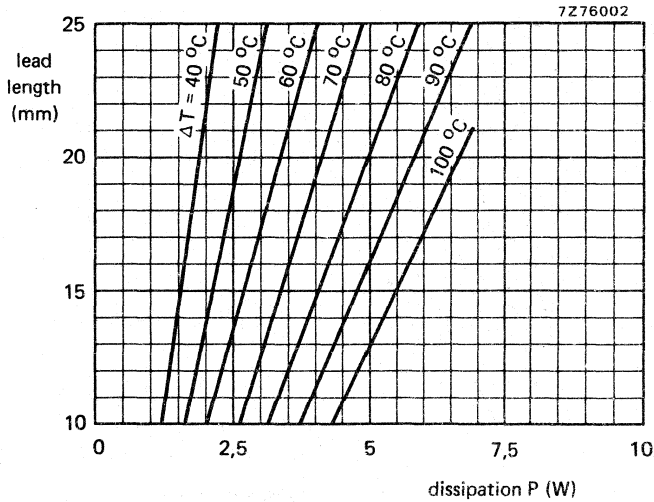

Fig. 3b Lead length as a function of the dissipation with the temperature rise at the end of the lead (soldering spot) as parameter, for style AC05.

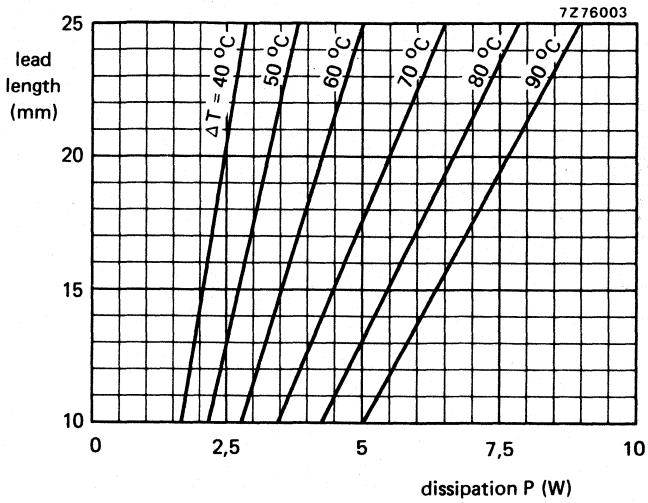

Fig. 3c Lead length as a function of the dissipation with the temperature rise at the end of the lead (soldering spot) as parameter, for style AC07.

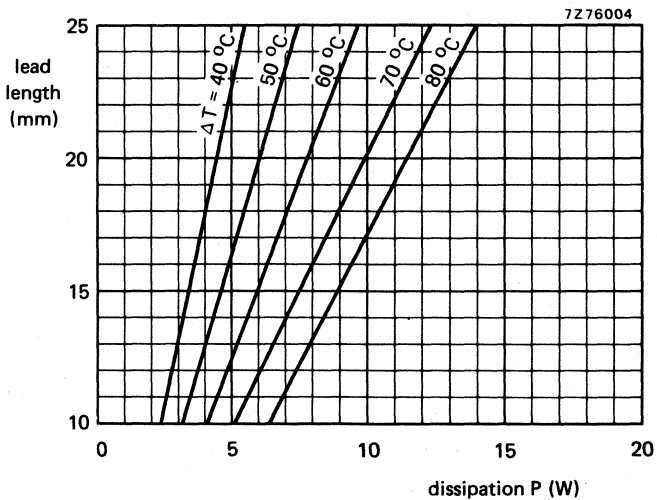

Fig. 3d Lead length as a function of the dissipation with the temperature rise at the end of the lead (soldering spot) as parameter, for style AC10.

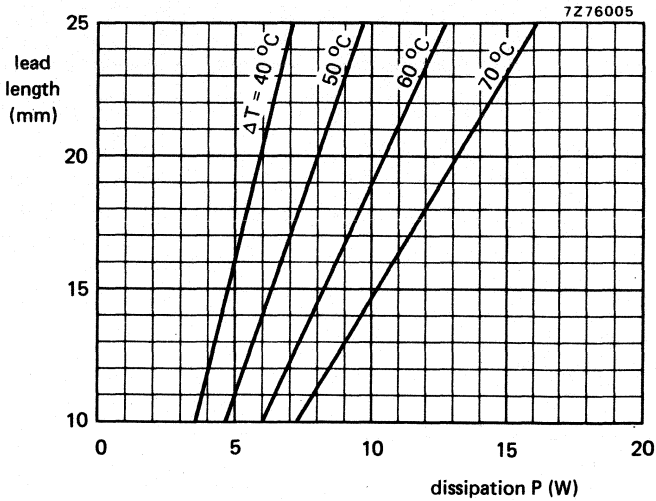

Fig. 3e Lead length as a function of the dissipation with the temperature rise at the end of the lead (soldering spot) as parameter, for style AC15.

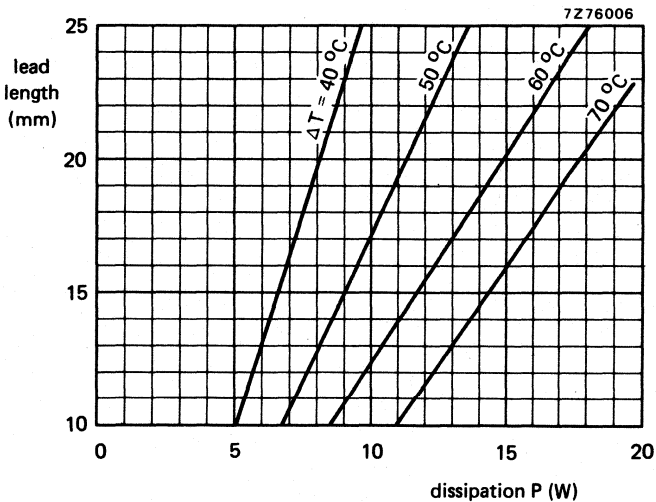

Fig. 3f Lead length as a function of the dissipation with the temperature rise at the end of the lead (soldering spot) as parameter, for style AC20.



### Marking

The nominal resistance (R for  $\Omega$ , K for  $k\Omega$ ), the tolerance on the resistance and the rated dissipation at  $T_{amb} = 40^\circ\text{C}$  are printed on the resistor body, e.g. 27 R 5% 4 W.

### ELECTRICAL DATA

#### Standard values of rated resistance and tolerance

Standard values of rated resistance (nominal resistance) are taken from the E24 series, tolerance  $\pm 5\%$  or  $\pm 10\%$  within the range  $0,1 \Omega$  to  $33 k\Omega$  as per Table 2. See the table "Standard series of values in a decade" at the back of the Handbook.

Table 2

type	rated dissipation (W)		resistance range $\Omega$	tol. %	catalogue number
	$T_{amb} = 40^\circ\text{C}$	$T_{amb} = 70^\circ\text{C}$			
AC04	4	3,5	0,10 - 8,2	10	2322 329 34 ...
			10 - 4700	5	2322 329 04 ...
AC05	5	4,7	0,10 - 8,2	10	2322 329 35 ...
			10 - 5600	5	2322 329 05 ...
AC07	7	5,8	0,10 - 8,2	10	2322 329 37 ...
			10 - 10 000	5	2322 329 07 ...
AC10	10	8,4	0,68 - 8,2	10	2322 329 40 ...
			10 - 15 000	5	2322 329 10 ...
AC15	15	12,5	0,82 - 8,2	10	2322 329 45 ...
			10 - 22 000	5	2322 329 15 ...
AC20	20	16	1,2 - 8,2	10	2322 329 50 ...
			10 - 33 000	5	2322 329 20 ...

Maximum permissible body temperature

350  $^\circ\text{C}$

Ambient temperature range

-40 to + 200  $^\circ\text{C}$

Temperature coefficient

-80 to + 140  $\cdot 10^{-6}/\text{K}$

Values < 10  $\Omega$

+600  $\cdot 10^{-6}/\text{K}$

Climatic category (IEC 68)

40/200/56

### COMPOSITION OF THE CATALOGUE NUMBER

The catalogue number in the above table is completed by inserting the resistance code: the first two figures of the resistance followed by:

7 for R = 0,1 to 0,82  $\Omega$

8 for R = 1 to 8,2  $\Omega$

9 for R = 10 to 91  $\Omega$

1 for R = 100 to 910  $\Omega$

2 for R = 1 to 91  $k\Omega$

3 for R = 10 to 33  $k\Omega$

## TESTS AND REQUIREMENTS

Essentially all tests are carried out according to the schedule of IEC publications 266 and 266A category 40/200/56 (rated temperature range  $-40$  to  $+200$  °C; damp heat, long term, 56 days) and along the lines of IEC publication 68. "Recommended basic climatic and mechanical robustness testing procedure for electronic components". In the following table the tests are listed with reference to the relevant clauses of IEC publications 266, 266A and 68; a short description is also given of the test procedure and requirements. In some instances deviations from the IEC recommendation were necessary for our method of specifying.

Table 4

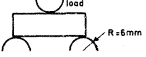
IEC 266 clause	IEC 68 test method	test	procedure	requirements
14		Robustness of resistor body	 load 200 $\pm 10$ N	no visible damage $\Delta R \leq 0,5\% + 0,05 \Omega$
15	U Ua Ub Uc	Robustness of terminations: Tensile all samples Bending half number of samples Torsion other half number of samples	 load 10 N; 10 s   load 5 N; 4 x 90° 2 x 180° in opposite directions	no visible damage $\Delta R$ max. 0,5% + 0,05 $\Omega$
16	T	Soldering	solderability: 2 s 230 °C, flux 600 thermal shock: 3 s 350 °C, 2,5 mm from body	good tinning, no damage $\Delta R$ max. 0,5% + 0,05 $\Omega$
17	Na	Rapid change of temperature	$\frac{1}{2}$ h $-40$ °C/ $\frac{1}{2}$ h $+200$ °C, 5 cycles	no visible damage $\Delta R$ max. 1% + 0,05 $\Omega$
18	Fc	Vibration	frequency 10-500 Hz, displacement 0,75 mm or acceleration 10g, three directions; total 6 h (3 x 2 h)	no visible damage $\Delta R$ max. 0,5% + 0,05 $\Omega$
19	Eb	Bump	4000 $\pm$ 10 bumps 390 m/s <sup>2</sup>	no visible damage $\Delta R$ max. 0,5% + 0,05 $\Omega$

IEC 266 clause	IEC68 test method	test	procedure	requirements
20		Climatic sequence		
20.2	Ba	Dry heat	16 h, 200 °C	
20.3	D	Damp heat (accel) 1st cycle	24 h; 55 °C; 95-100% R.H.	
20.4	Aa	Cold	2 h; -40 °C	
20.5	M	Low air pressure	1 h; 8,5 kPa; 15-35 °C	
20.6	D	Damp heat (accel) re- maining cycles	5 days; 55 °C; 95-100% R.H.	after 24 h at $P_n$ $\Delta R$ max. 1% + 0,05 $\Omega$
21	Ca	Damp heat steady state	56 days; 40 °C; 90-95% R.H. dissipation $\leq$ 0,01 $P_n$	$\Delta R$ max. 1% + 0,05 $\Omega$
22	—	Endurance	1000 h at 70 °C	$\Delta R$ max. 5%
23			1000 h at 200 °C	$\Delta R$ max. 5%
13.6		Overload	10 x $P_n$ , 5 s	$\Delta R$ max. 2%

**STANDARD PACKAGING**

Resistors AC04, AC05 and AC07 are supplied on bandoliers of 500, in ammpack. Types AC10, AC15 and AC20 are supplied loose in cardboard boxes of 100.

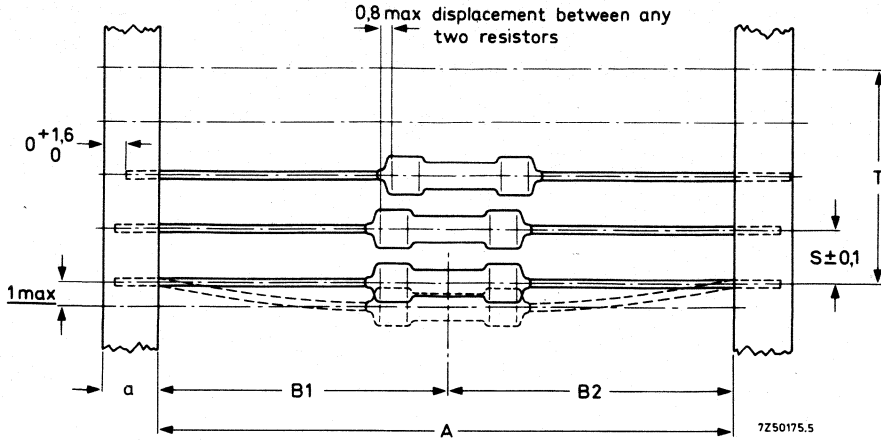

Fig. 4.

type	a ± 0,5	A ± 4	B1 - B2 ± max.	S (spacing)	T (max. deviation of spacing)
AC04	5 or 6	66	1,2	10	} 1 mm per 10 spacings 0,5 mm per 5 spacings
AC05	6	66	1,2	10	
AC07	6	74	1,2	10	





## CEMENTED WIREWOUND RESISTORS

These wirewound resistors are specially designed to dissipate high powers in a small volume.

### QUICK REFERENCE DATA

Resistance range		from 0,1 $\Omega$ to 12 k $\Omega$ , E24 or E12 series
Resistance tolerance		$\pm 5\%$ or $\pm 10\%$
Maximum body temperature		350 $^{\circ}\text{C}$
Rated dissipation at $T_{\text{amb}} = 70^{\circ}\text{C}$	ACL01	1 W
	ACL02	2 W
	ACL03	3 W
Basic specification		IEC publication 266
Climatic category (IEC 68, DIN 40 045)		40/200/56
Stability after:		
load, 1000 h		$\Delta R/R$ max. 3%
climatic tests		$\Delta R/R$ max. 5%
short time overload		$\Delta R/R$ max. 2%

### DESCRIPTION

The resistor element is wound in a single layer on a glass-fibre rod. Metal caps are pressed over the ends of the rod. The ends of the resistance wire and the leads are connected to the caps by welding. Tinned copper-clad iron leads with poor heat conductivity are employed permitting the use of relatively short leads to obtain stable mounting. The resistor is coated with a green silicon cement which is non-inflammable and cannot drip even at high overloads.

ACL01  
 ACL02  
 ACL03

**MECHANICAL DATA**  
 Outlines

Dimensions in mm

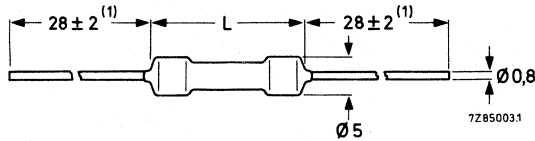

(1) If taped: 35 mm.

Fig. 1 Standard version with straight leads.

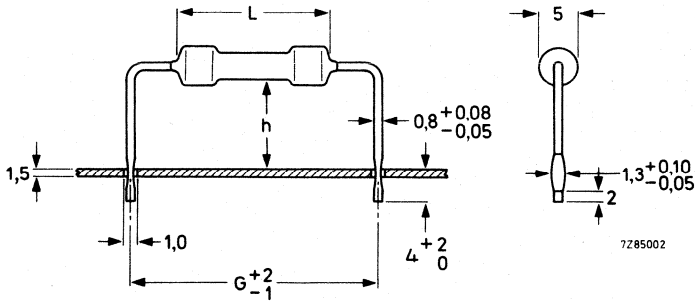

Fig. 2 Special version with cropped and formed leads, available on special request.

Table 1

type	L <sub>max</sub>	G	h
ACL01	16	20	8 or 15
ACL02	24	27,5	8 or 15
ACL03	34	—	8 or 15

Mass (per 100 pieces)

ACL01	66 g
ACL02	79 g
ACL03	96 g

**Mounting**

The resistors must be mounted in such a way that:

- no stress is exerted on the leads so as to allow thermal expansion over the wide permissible temperature range.
- nearby components and materials are not affected by the dissipated heat.
- the temperature at the soldering spots of the leads does not reach the melting point of the solder.

The temperature rise of the resistor body and of the leads at various distances from the body is given as a function of the dissipation for the different resistor styles in Figs 3 to 5.

**Marking**

Each resistor is marked with:

- resistance value (R for  $\Omega$ , K for  $k\Omega$ )  
e.g. 27  $\Omega$  = 27R  
15  $k\Omega$  = 15K
- tolerance on resistance in %
- rated dissipation at  $T_{amb} = 70^\circ C$

Example: 10R 5%  
1W

**ELECTRICAL DATA**

Table 2, standard range

type	rated dissipation (W) $T_{amb} = 70^\circ C$	resistance range $\Omega$	tol. %	series	catalogue number
ACL01	1,0	0,10 – 8,2	10	E12	2306 300 02...
		10 – 3900	5	E24	2306 300 03...
ACL02	2,0	0,18 – 8,2	10	E12	2306 301 02...
		10 – 8200	5	E24	2306 301 03...
ACL03	3,0	0,27 – 8,2	10	E12	2306 302 02...
		10 – 12 000	5	E24	2306 302 03...

Maximum permissible body temperature

350  $^\circ C$

Ambient temperature range

–40 to +200  $^\circ C$

Temperature coefficient

–50 to +140  $\cdot 10^{-6}/K$

Values < 10  $\Omega$

+600  $\cdot 10^{-6}/K$

Climatic category (IEC 68)

40/200/56

**Composition of the catalogue number**

In the catalogue number (Table 2) replace the first two dots by the first two digits of the resistance value. Replace the third dot by a figure according to the following table:

0,1	–	0,91	Ω : 7
1	–	9,1	Ω : 8
10	–	91	Ω : 9
100	–	910	Ω : 1
1 000	–	9 100	Ω : 2
10 000	–	22 000	Ω : 3

7Z82403



Fig. 3 Temperature rise of the resistor body as a function of the dissipation.

— for lead length of 18 mm  
 - - - for lead length of 10 mm.

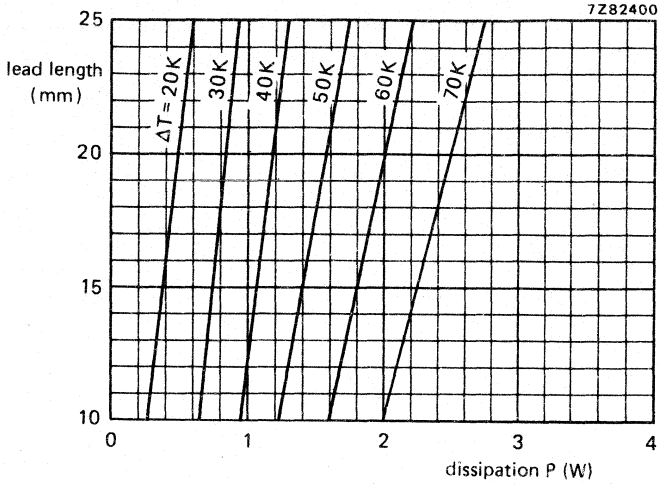

Fig. 4 Lead length as a function of the dissipation with the temperature rise at the end of the lead (soldering spot) as parameter, for style ACL01.

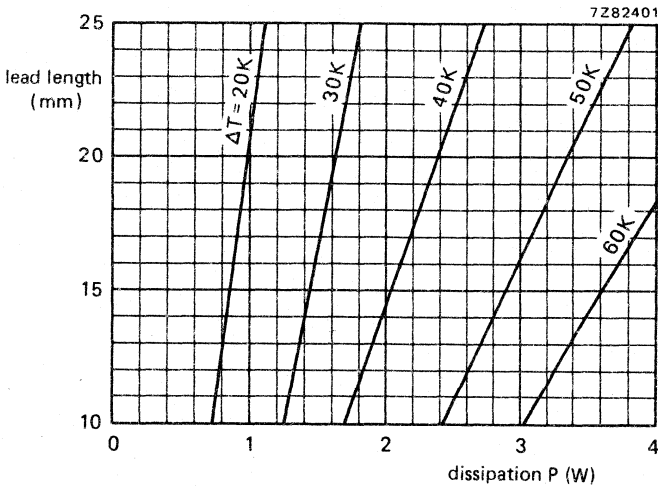

Fig. 5 Lead length as a function of the dissipation with the temperature rise at the end of the lead (soldering spot) as parameter, for style ACL02.



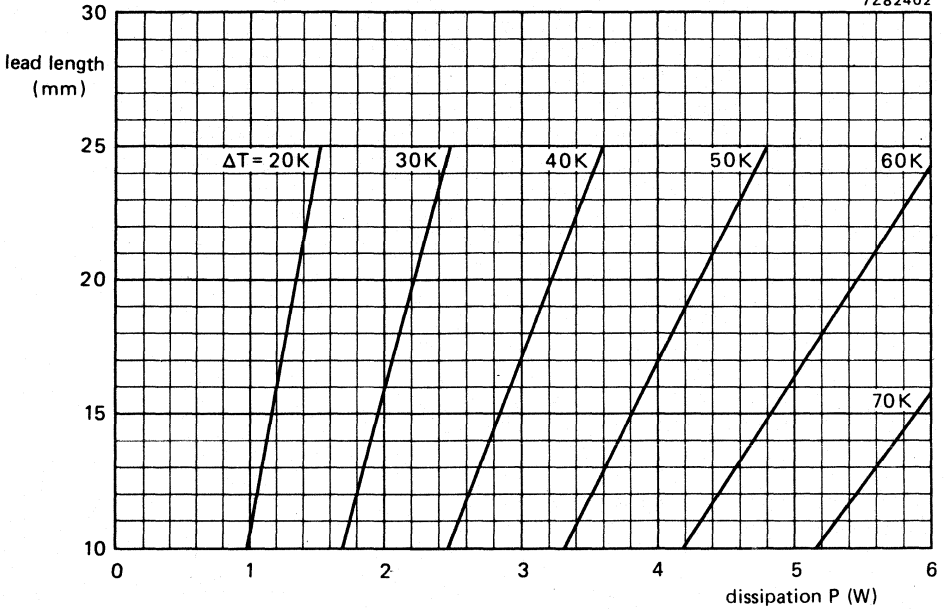

Fig. 6 Lead length as a function of the dissipation with the temperature rise at the end of the lead (soldering spot) as parameter, for style ACL03.

## TESTS AND REQUIREMENTS (in accordance with IEC publication 266 and 266 A)

IEC 266 clause	IEC 68 test method	test	procedure	requirements
14		robustness of resistor body	load $200 \pm 10$ N	no visible damage $\Delta R \leq 0,5\% + 0,05 \Omega$
15	U Ua Ub Uc	robustness of terminations: tensile, all samples bending, half number of samples torsion, other half number of samples	load 10 N, 10 s load 5 N, 4 x 90° 2 x 180° in opposite directions	no visible damage $\Delta R \leq 0,5\% + 0,05 \Omega$
16	T	soldering: solderability thermal shock	2 s 230 °C, flux 600 3 s 350 °C, 2,5 mm from body	good tinning, no damage no damage, $\Delta R \leq 0,5\% + 0,05 \Omega$
17	Na	rapid change of temperature	3 h -40 °C/3 h +200 °C, 5 cycles	no visible damage $\Delta R \leq 1\% + 0,05 \Omega$
18	Fc	vibration	10 – 500 Hz, 0,75 mm or 10g, whichever is the less, for 6 h	no visible damage $\Delta R \leq 0,5\% + 0,05 \Omega$
19	Eb	bumping	390 m/s <sup>2</sup> , 4000 ± 10 bumps	no visible damage $\Delta R \leq 0,5\% + 0,05 \Omega$
20 20.2 20.3 20.4 20.5 20.6	Ba Aa M D	climatic sequence: dry heat damp heat (acc) 1st cycle cold low air pressure damp heat (acc) remaining cycles	16 h 200 °C 1 day 55 °C, 95-100% R.H. 2 h -40 °C 1 h 8,5 kN/m <sup>2</sup> , 15-35 °C 5 days 55 °C, 95-100% R.H.	final measurements  after 24 h at rated diss. $\Delta R \leq 5\%$
21	Ca	damp heat long term	56 days 40 °C, 90-95% R.H., 0,01 P <sub>rated</sub>	$\Delta R \leq 5\%$ , after 24 h at rated diss. $\Delta R \leq 5\%$
13.6		overload	10 times rated dissipation, 5 s	$\Delta R \leq 2\%$
22 23		endurance endurance	1000 h at room temperature 1000 h at upper category temp.	$\Delta R \leq 3\%$ $\Delta R \leq 3\%$

ACL01  
 ACL02  
 ACL03

**STANDARD PACKAGING**

Loose: 500 pieces per box  
 On bandolier: on special request only.

**Configuration of bandolier**

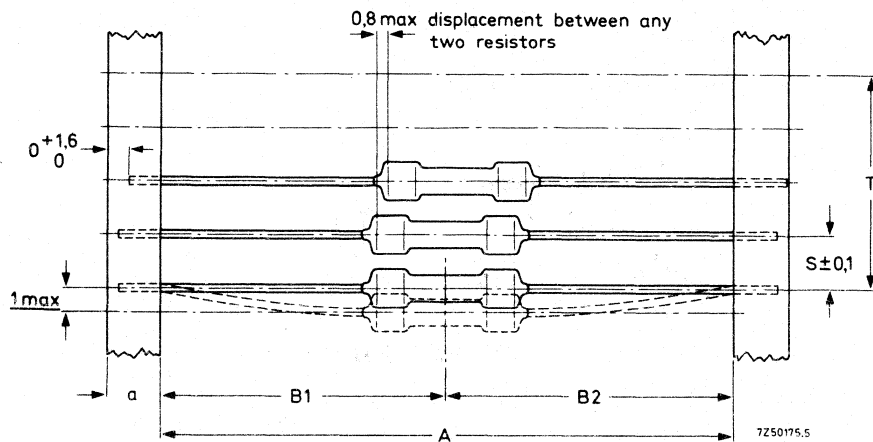

Fig. 7.

type	a ± 0,5	A	B1 – B2 ± max.	S (spacing)	T (maximum deviation of spacing)
ACL01	6	81 ± 2	1,2	10	} 1 mm per 10 spacings 0,5 mm for 5 spacings
ACL02	6	87 ± 2	1,2	10	
ACL03	6	97 ± 2	1,2	10	



## ENAMELLED WIREWOUND RESISTORS

### QUICK REFERENCE DATA

Resistance ranges		4,7 $\Omega$ to 100 k $\Omega$ , E24 or E12 series
Resistance tolerance		$\pm 5\%$ or $\pm 10\%$
Max. body temperature (hot spot)		400 $^{\circ}\text{C}$
Rated dissipation at $T_{\text{amb}} = 70^{\circ}\text{C}$	WR0617E	4 W
	WR0825E	7 W
	WR0842E	11 W
	WR0865E	17 W
Basic specification		IEC publication 266, type 2
Climatic category (IEC 68)		55/200/56
Stability after:		
1000 h max. load		$\Delta R/R$ max. 5%
climatic tests		$\Delta R/R$ max. 1%
dip-soldering test		$\Delta R/R$ max. 0,5%
short time overload		$\Delta R/R$ max. 2%

### APPLICATION

As power resistors in electrical and electronic circuitry.

### DESCRIPTION

These resistors have a single layer of resistance wire wound on a ceramic body. Leads of solder-coated copper-clad wire are secured to caps which are force-fitted on to the ends of the ceramic body. The resistor is coated with brown enamel.

### MECHANICAL DATA

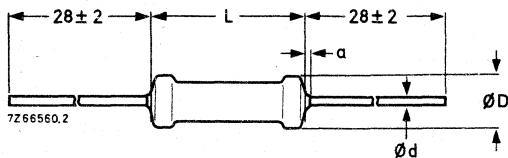

Fig. 1.

Table 1

type	$D_{\text{max}}$	$L_{\text{max}}$	$d$	$a_{\text{max}}$
WR0617E	6	19	0,7	3
WR0825E	8	27	0,8	3
WR0842E	8	44	0,8	3
WR0865E	8	67	0,8	3

#### Note

The lead length ( $28 \pm 2$  mm)  
only applies to untaped resistors,  
i.e. types WR0842E and WR0865E.

The length of the resistor body is measured by inserting the leads into the holes of two identical gauge plates and by moving these plates parallel to each other until the resistor body is clamped without deformation (see IEC publication 294). The diameter of the holes in the gauge plate is 1,0 mm.

**Mass**

WR0617E  
WR0825E  
WR0842E  
WR0865E

**Mounting**

The resistors must be mounted in such a way that:

- no stress is exerted on the leads so as to allow thermal expansion over the wide temperature range.
- nearby components and materials are not affected by the dissipated heat.

**Marking**

Each resistor is marked with:

- resistance value (R for  $\Omega$ , K for  $k\Omega$ )  
e.g. 27  $\Omega$  = 27R  
27  $k\Omega$  = 27K
- tolerance on resistance in %
- rated dissipation at  $T_{amb} = 70\text{ }^\circ\text{C}$

Example: 27R 10%  
4W

**ELECTRICAL DATA**

Table 2

type	rated dissipation at $T_{amb} = 70\text{ }^\circ\text{C}$ W	resistance range $\Omega$	tol. %	series *	catalogue number
WR0617E	4	4,7 – 4700	5	E24	2322 330 22 ...
		4,7 – 47	10	E12	2322 330 21 ...
WR0825E	7	6,8 – 27 000	5	E24	2322 330 32 ...
		6,8 – 27	10	E12	2322 330 31 ...
WR0842E	11	10 – 56 000	5	E24	2322 330 42 ...
WR0865E	17	15 – 100 000	5	E24	2322 330 52 ...

Maximum body temperature (hot spot) 400  $^\circ\text{C}$   
 Ambient temperature range –55 to +200  $^\circ\text{C}$   
 Temperature coefficient –80 to +140  $\cdot 10^{-6}/\text{K}$   
 Climatic category (IEC 68) 55/200/56

\* See the table "Standard series of values in a decade" at the back of this book.

## COMPOSITION OF THE CATALOGUE NUMBER

The catalogue number in Table 2 is completed by inserting the resistance code: the first two significant figures of the resistance value (in  $\Omega$ ) followed by:

- 8 for R of 4,7 to 9,1  $\Omega$
- 9 for R of 10 to 91  $\Omega$
- 1 for R of 100 to 910  $\Omega$
- 2 for R of 1 to 9,1 k $\Omega$
- 3 for R of 10 to 91 k $\Omega$
- 4 for R of 100 k $\Omega$

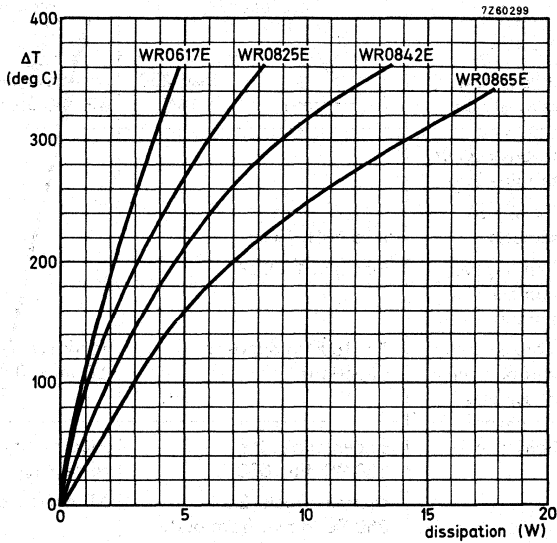
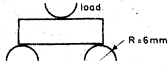

Fig. 2 Temperature rise ( $\Delta T$ ) of the resistor body as a function of the dissipation. Distance between cap and solder joint is 10 mm.

### TESTS AND REQUIREMENTS

Essentially all tests are carried out according to the schedule of IEC publications 266 and 266A, category 55/200/56 (rated temperature range  $-55\text{ }^{\circ}\text{C}$  to  $+200\text{ }^{\circ}\text{C}$ ; damp heat, long term, 56 days) and along the lines of IEC publication 68, "Recommended basic climatic and mechanical robustness testing procedure for electronic components". In the following table the tests are listed with reference to the relevant clauses of IEC publications 266, 266A and 68; a short description is also given of the test procedure and requirements. In some instances deviations from the IEC recommendation were necessary for our method of specifying.

Table 3

IEC 266 clause	IEC 68 test method	test	procedure	requirements
14		Robustness of resistor body	 load 200 $\pm 10\text{N}$	no visible damage $\Delta R \leq 0,5\%$ or $0,05\ \Omega$
15	U Ua Ub Uc	Robustness of terminations Tensile all samples Bending half number of samples Torsion other half number of samples	load 10N; 10 s load 5N; $4 \times 90^{\circ}$  $2 \times 180^{\circ}$ in opposite directions	no visible damage $\Delta R \text{ max. } 0,5\% + 0,05\ \Omega$
16	T	Soldering	solderability: 2 s $230\text{ }^{\circ}\text{C}$ , flux 600 thermal shock: 3 s $350\text{ }^{\circ}\text{C}$ , 6 mm from body	good tinning, no damage $\Delta R \text{ max. } 0,5\% + 0,05\ \Omega$
17	Na	Rapid change of temperature	$\frac{1}{2}\text{ h } -55\text{ }^{\circ}\text{C}/\frac{1}{2}\text{ h } + 200\text{ }^{\circ}\text{C}$ , 5 cycles	no visible damage $\Delta R \text{ max. } 1\%$
18	Fc	Vibration	frequency 10-500 Hz, displacement 0,75 mm or acceleration 10g, three directions; total 6 h ( $3 \times 2\text{ h}$ )	no visible damage $\Delta R \text{ max. } 0,5\% + 0,05\ \Omega$
19	Eb	Bump	$4000 \pm 10$ bumps $390\text{ m/s}^2$	no visible damage $\Delta R \text{ max. } 0,5\% + 0,05\ \Omega$

IEC 266 clause	IEC 68 test method	test	procedure	requirements
20		Climatic sequence		
20.2	Ba	Dry heat	16 h, 200 °C	
20.3	D	Damp heat (accel) 1st cycle	24 h; 55 °C; 95-100% R.H.	
20.4	Aa	Cold	2 h; -55 °C	
20.5	M	Low air pressure	1 h; 8,5 kPa; 15-35 °C	
20.6	D	Damp heat (accel) remaining cycles	5 days; 55 °C; 95-100% R.H.	after 24 h at $P_n$ $\Delta R$ max. 5%
21	Ca	Damp heat steady state	56 days; 40 °C; 90-95% R.H. dissipation $\leq 0,01 P_n$	after 24 h at $P_n$ $\Delta R$ max. 1%
22	—	Endurance	1000 h at 70 °C	$\Delta R$ max. 5%
23	—		1000 h at 200 °C	$\Delta R$ max. 5%
13.6	—	Overload	10 x $P_n$ , 5 s 2 x $P_n$ , 10 min.	$\Delta R$ max. 2%



**STANDARD PACKAGING**

type	number per box	
	bandolier	singles
WR0617E	500	
WR0825E	500	
WR0842E		50
WR0865E		50

**Configuration of bandolier**

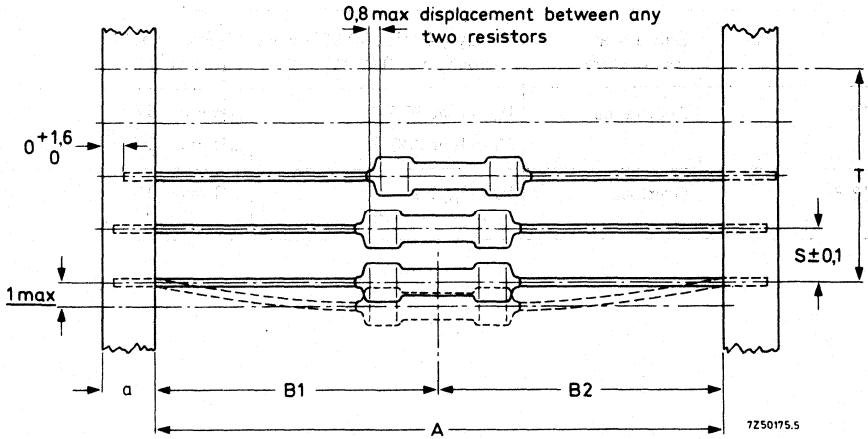

Fig. 3.

type	a ± 0,5	A ± 1,6	B1-B2 ± max.	S (spacing)	T (max. deviation of spacing)
WR0617E	5	66,7	1,2	10	} 1 mm per 10 spacings } 0,5 mm per 5 spacings
WR0825E	6	74	1,2	10	

## RECTANGULAR WIREWOUND RESISTORS

### QUICK REFERENCE DATA

Resistance range	0,15 to 22 k $\Omega$ , E24/E12 series	
Resistance tolerance	$\pm 5\%$ or $\pm 10\%$	
Max. permissible body temperature (hot spot)	350 °C	
Rated dissipation of T <sub>amb</sub> = 70 °C	EH04: 4 W; EH05: 5 W; EH07: 7 W; EH09: 9 W; EH17: 17 W	
Basic specification	IEC 266	
Climatic category (IEC 68)	40/200/56	
Stability after		
load	$\Delta R/R$ max.	5%
climatic tests	$\Delta R/R$ max.	3%
short time overload	$\Delta R/R$ max.	2%

### APPLICATION

The resistors are for high dissipation in a small volume. The rectangular shape facilitates mounting against a flat surface.

### DESCRIPTION

The resistor element is wound in a single layer on a glass fibre rod. Metal caps are pressed over the ends of rod and wire. Tinned copper leads are welded to the caps. The resistor is mounted in a rectangular, sandfilled ceramic case. The ends of the body are impregnated with a protective silicon resin. The resistors are resistant against aggressive solvents.

### MECHANICAL DATA

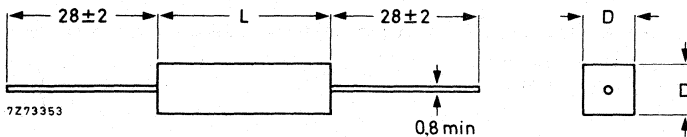

Fig. 1.

Table 1

type	D <sub>max</sub>	L <sub>max</sub>
EH04	7,2	20
EH05	7,2	26
EH07	7,2	36
EH09	7,2	46
EH17	10,7	62

# EH04 EH05 EH07 EH09 EH17

Mass (per 100)

EH04: 295 g; EH05: 319 g; EH07: 400 g

EH09: 510 g; EH17: 1400 g

## Mounting

The resistors must be mounted in such a way that:

- no stress is exerted on the leads so as to allow thermal expansion over the wide permissible temperature range.
- nearby components and materials are not affected by the dissipated heat.
- the temperature at the soldering spots of the leads does not reach the melting point of the solder.

The temperature rise of the resistor body and of leads of different lengths is given as a function of the dissipation in Fig. 2.

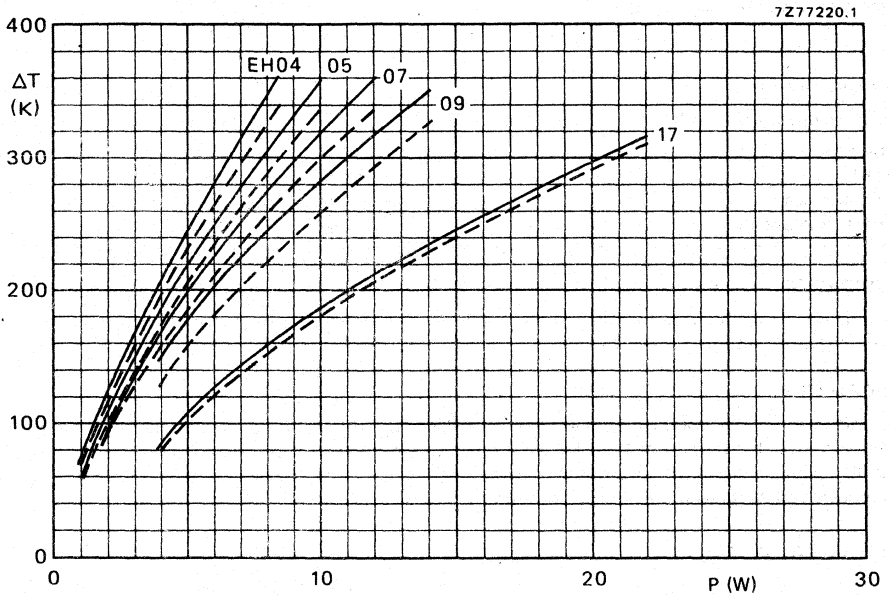

Fig. 2 Hot spot temperature rise ( $\Delta T$ ) as a function of the dissipation ( $P$ ) at two lead lengths.

————— for lead length of 22 mm

- - - - - for lead length of 28 mm



**Marking**

The nominal resistance (R for  $\Omega$ , k for k $\Omega$ ), the tolerance on the resistance and the rated dissipation at  $T_{amb} = 70^\circ\text{C}$  are printed on the resistor body, e.g. 27R 5% 9 W.

**ELECTRICAL DATA**

**Standard values of rated resistance**

Standard values of rated resistance (nominal resistance) are taken from the E24 series, tolerance  $\pm 5\%$  and E12 series, tolerance  $\pm 10\%$ , within the range of 0,1  $\Omega$  to 22 k $\Omega$  as per Table 2. See the table "Standard series of values in a decade" at the back of the Handbook.

**Table 2**

type	rated dissipation (W) at $T_{amb} = 70^\circ\text{C}$ W	resistance range	tolerance	series	catalogue number
		$\Omega$	%		
EH04	4	0,1 – 8,2	10 *	E12	2306 335 02...
		10 – 3900	5	E24	2306 335 03...
EH05	5	0,15 – 8,2	10 *	E12	2306 330 02...
		10 – 6800	5	E24	2306 330 03...
EH07	7	0,27 – 8,2	10 *	E12	2306 331 02...
		10 – 12000	5	E24	2306 331 03...
EH09	9	0,33 – 8,2	10 *	E12	2306 332 02...
		10 – 15000	5	E24	2306 332 03...
EH17	17	0,47 – 8,2	10 *	E12	2306 333 02...
		10 – 22000	5	E24	2306 333 03...

Breakdown r.m.s. voltage of encapsulation	min. 2000 V
Max. permissible body temperature (hot spot)	350 $^\circ\text{C}$
Ambient temperature range	-40 to +200 $^\circ\text{C}$
Temperature coefficient 0,15 – 5,1 $\Omega$	$\leq + 600 \cdot 10^{-6}/\text{K}$
5,6 – 22000 $\Omega$	-50 to +140 $\cdot 10^{-6}/\text{K}$
Climatic category (IEC66)	40/200/56

**COMPOSITION OF THE CATALOGUE NUMBER**

The catalogue number in Table 2 is completed by inserting the resistance code: the first two figures of the resistance followed by:

7 for R = 0,1 to 0,82 $\Omega$	9 for R = 10 to 91 $\Omega$	2 for R = 1 to 9,1 k $\Omega$
8 for R = 1 to 8,2 $\Omega$	1 for R = 100 to 910 $\Omega$	3 for R = 10 to 22 k $\Omega$

\* Tolerance of  $\pm 5\%$  on request.

TESTS AND REQUIREMENTS

Essentially all tests are carried out according to the schedule of IEC publications 266 and 266A category 40/200/56 (rated temperature range  $-40$  to  $+200$  °C; damp heat, long term, 56 days) and along the lines of IEC publication 68. "Recommended basic climatic and mechanical robustness testing procedure for electronic components". In the following table the tests are listed with reference to the relevant clauses of IEC publications 266, 266A and 68, a short description is also given of the test procedure and requirements. In some instances deviations from the IEC recommendation were necessary for our method of specifying.

Table 3

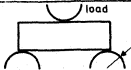
IEC 266 clause	IEC 68 test method	test	procedure	requirements
14		Robustness of resistor body	 load 200 $\pm$ 10 N	no visible damage $\Delta R \leq 0,5\% + 0,05 \Omega$
15	U Ua Ub Uc	Robustness of terminations. Tensile all samples. Bending half number of samples Torsion other half number of samples	load 10N; 10 s load 5N; 4 x 90° 2 x 180° in opposite directions	no visible damage $\Delta R$ max. 0,5% + 0,05 $\Omega$
16	T	Soldering	solderability: 2 s 230 °C, flux 600 thermal shock: 3 s 350 °C, 2,5 mm from body	good tinning, no damage $\Delta R$ max. 0,5% + 0,05 $\Omega$
17	Na	Rapid change of temperature	½ h $-40$ °C/½ h $+200$ °C, 5 cycles	no visible damage $\Delta R$ max. 1%
18	Fc	Vibration	frequency 10-500 Hz, displacement 0,75 mm or acceleration 10 g three directions; total 6 h (3 x 2 h)	no visible damage $\Delta R$ max. 0,5% + 0,05 $\Omega$
19	Eb	Bump	4000 $\pm$ 10 bumps 390 m/s <sup>2</sup>	no visible damage $\Delta R$ max. 0,5% + 0,05 $\Omega$
20 20.2 20.3 20.4 20.5 20.6	Ba D Aa M D	Climatic sequence Dry heat Damp heat (accel.) 1st cycle Cold Low air pressure Damp heat (accel.) remaining cycles	16 h, 200 °C 24 h; 55 °C; 95-100% R.H. 2 h; $-40$ °C 1 h; 8,5 x Pa; 15-35 °C 5 days; 55 °C; 95-100% R.H.	after 24 h at P <sub>n</sub> $\Delta R$ max. 3%

IEC 266 clause	IEC 68 test method	test	procedure	requirements
21	Ca	Damp heat steady state	56 days; 40 °C; 90-95% R.H. dissipation: $\leq 0,01 P_n$	$\Delta R$ max. 3%
22 23	—	Endurance	1000 h at 70 °C 1000 h at 200 °C	$\Delta R$ max. 5% $\Delta R$ max. 5%
13.6		Overload	$10 \times P_n$ , 5 s	$\Delta R$ max. 2%





## WIREWOUND RESISTORS WITH SIDE TERMINATIONS

### QUICK REFERENCE DATA

	cemented	enamelled
Type	2322 323 . . . . .	2322 321 . . . . .
Resistance range	1 Ω to 11 kΩ E12/E24 series	160 Ω to 120 kΩ E24 series
Resistance tolerance	± 5%, ± 10%	± 5%
Abs. max. dissipation at $T_{amb} = 40\text{ °C}$	8 to 250 W	8 to 100 W
Temperature coefficient	-50 to + 140 · 10 <sup>-6</sup> /K	
Climatic category (IEC68)	55/155/56	

### DESCRIPTION

The resistors have one layer of resistance wire on a ceramic rod. They are cement or enamel-coated for mechanical protection. They have side terminations.

### MECHANICAL DATA

#### 1. Resistors $P_n \leq 40\text{ W}$

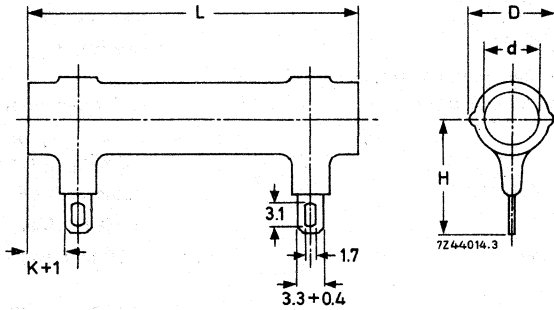

Fig. 1.

Table 1

$P_{nom}$ W	$D_{max}$	$d_{min}$	K	L	H
8	11,5	5	2,5	26 <sup>-2</sup>	14
10	11,5	5	4	41 <sup>-2</sup>	14
16	11,5	5	4	62,5 <sup>-2</sup>	14
25	16	8	4	64 <sup>-2</sup>	20
40	16	8	4	103 <sup>-5</sup>	20

2. Resistors  $P_n \geq 60 \text{ W}$

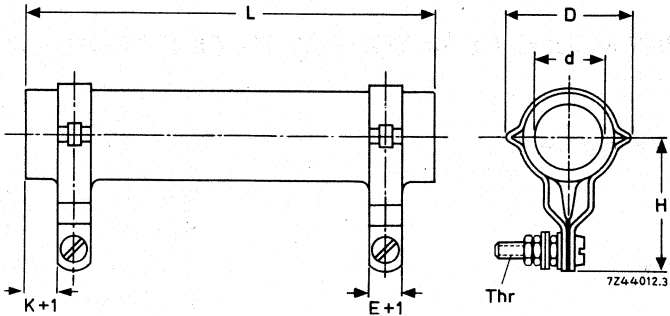

Fig. 2.

Table 2

$P_{nom}$ W	$D_{max}$	$d_{min}$	E	H	K	$L_{max}$	Thr
60	32	12,5	8,5	33	6	103	M4
100	32	12,5	8,5	33	6	165	M4
160	44	20	10	40	8	165	M5
250	44	20	10	40	8	256	M5

TECHNICAL DATA

Max. dissipation at 40 °C (=  $P_n$ )

Max. dissipation at > 40 °C

Max. dissipation, mounted, with a bolt through the cylinder, against a metal plate

Max. overload at 40 °C

Resistance values (see Table 3)

Tolerance

Temperature coefficient

Stability

after load

after climatic tests

Insulation

Ambient temperature range

Climatic category (IEC 68)

see Table 3

see Fig. 3

1,2 x max. dissipations given above

2 x  $P_{nom}$  for 10 min

10 x  $P_{nom}$  for 5 s

measured at  $P = 0,1 P_{nom}$

± 5% (± 10%)

-50 to + 140 · 10<sup>-6</sup>/K

$\Delta R/R$ , max. 5%

$\Delta R/R$ , max. 3%

the coating is non-insulating

-55 to + 155 °C

55/155/56

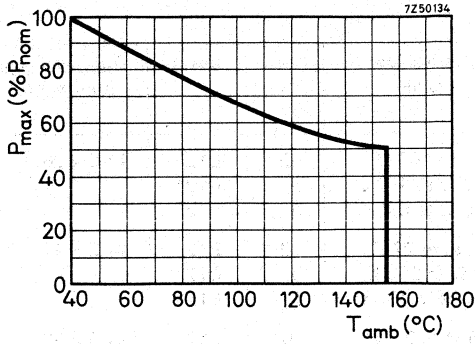

Fig. 3 Maximum dissipation as a function of the ambient temperature. With a bolt through the resistor, mounted against a metal plate, P<sub>max</sub> can be multiplied by 1,2.

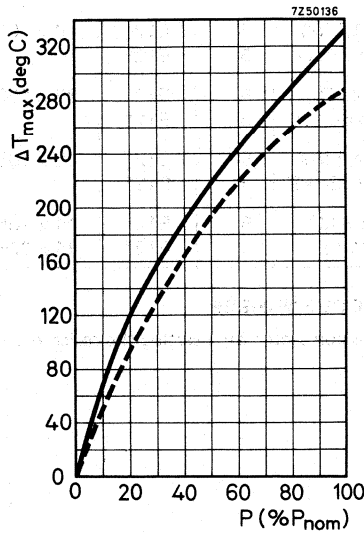

Fig. 4 Maximum temperature rise as a function of the dissipation. The dotted line refers to mounting with bolt and metal plate.

Table 3

coating	$P_{nom}$ W	resistance range	tol. %	series	$D_{max} \times L_{max}$ (mm x mm)	catalogue number: 2322 followed by
cement	8	1 $\Omega$ to 100 $\Omega$	10	E12	11,5 x 26	323 14 ...
		110 $\Omega$ to 150 $\Omega$	5	E12*		323 34 ...
enamel		160 $\Omega$ to 6,8 k $\Omega$	5	E12*		321 34 ...
cement	10	1,2 $\Omega$ to 27 $\Omega$	10	E12	11,5 x 41	323 12 ...
		30 $\Omega$ to 300 $\Omega$	5	E12*		323 32 ...
enamel		330 $\Omega$ to 12 k $\Omega$	5	E12*		321 32 ...
cement	16	1,5 $\Omega$ to 2,7 $\Omega$	10	E12	11,5 x 62,5	323 10 ...
		3 $\Omega$ to 620 $\Omega$	5	E12*		323 30 ...
enamel		680 $\Omega$ to 24 k $\Omega$	5	E12*		321 30 ...
cement	25	2,7 $\Omega$ to 15 $\Omega$	10	E12	16 x 64	323 08 ...
		16 $\Omega$ to 820 $\Omega$	5	E12*		323 28 ...
enamel		1 k $\Omega$ to 39 k $\Omega$	5	E12*		321 28 ...
cement	40	4,7 $\Omega$ to 1,6 k $\Omega$	5	E12*	16 x 103	323 26 ...
		1,8 k $\Omega$ to 75 k $\Omega$	5	E12*		321 26 ...
enamel						
cement	60	3 $\Omega$ to 2,2 k $\Omega$	5	E12*	32 x 103	323 24 ...
		2,4 k $\Omega$ to 68 k $\Omega$	5	E12*		321 24 ...
enamel						
cement	100	6,8 $\Omega$ to 4,3 k $\Omega$	5	E12*	32 x 165	323 23 ...
		4,7 k $\Omega$ to 120 k $\Omega$	5	E12*		321 23 ...
enamel						
cement	160	10 $\Omega$ to 6,8 k $\Omega$	5	E12*	44 x 165	323 22 ...
cement	250	16 $\Omega$ to 11 k $\Omega$	5	E12*	44 x 256	323 21 ...

### COMPOSITION OF THE CATALOGUE NUMBER

The catalogue number in Table 3 is completed by inserting the resistance code; the first two figures of the resistance in  $\Omega$ , followed by:

- 8 for R = 1 to 8,2  $\Omega$
- 9 for R = 10 to 82  $\Omega$
- 1 for R = 100 to 820  $\Omega$
- 2 for R = 1 to 8,2 k $\Omega$
- 3 for R = 10 to 82 k $\Omega$
- 4 for R = 100 to 120 k $\Omega$

\* Resistance values of the E24 series are available on request. See the table "Standard Series of values in a decade" at the back of the handbook.



## ADJUSTABLE WIREWOUND RESISTORS

## QUICK REFERENCE DATA

	cemented	enamelled
Type	2322 324 . . . . .	2322 322 . . . . .
Resistance range	1,2 $\Omega$ to 11 k $\Omega$ E12/E24 series	330 $\Omega$ to 47 k $\Omega$ E12 series
Resistance tolerance	$\pm 5\%$ , $\pm 10\%$	$\pm 5\%$
Abs. max. dissipation at $T_{amb} = 40\text{ }^{\circ}\text{C}$	10 to 250 W	10 to 100 W

## DESCRIPTION

The resistors have one layer of resistance wire on a ceramic tube and have side terminations. They are cement or enamel-coated for mechanical protection. A strap, fitted with a silver contact, may be positioned along an uncoated strip.

## MECHANICAL DATA

1. Resistors  $P_n \leq 40\text{ W}$ 

Fig. 1.

Table 1

$P_n$ W	$D_{max}$	$d_{min}$	H	K	E	$L_{max}$	B	A
10	11,5	4,2	14	4	3,3	41	5	2,8
16	11,5	4,2	14	4	3,3	62,5	5	2,8
25	16	7,2	20	4	3,3	64	6	3,2
40	16	7,2	20	4	3,3	103	6	3,2

2. Resistors  $P_n \geq 60$  W

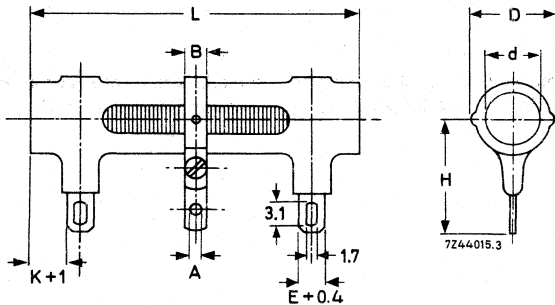
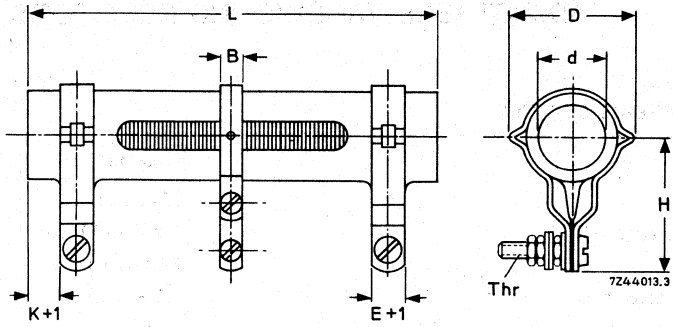

Fig. 2.

Table 2

$P_n$ W	$D_{max}$	$d_{min}$	H	K	E		B	thread
60	32	12,5	33	6	8,5	103	6	M4
100	32	12,5	33	6	8,5	165	6	M4
160	44	20	40	8	10	165	8	M5
250	44	20	40	8	10	256	8	M5

TECHNICAL DATA

The technical performance is identical to that of the non-adjustable wirewound resistors with side terminations, 2322 323 . . . . . and 2322 321 . . . . . See pages B118 and B119.

Table 3

coating	$P_n^*$ W	resistance range	tol. %	series **	short circuit* % $R_n$	$D_{max} \times L_{max}$ (mm x mm)	catalogue number 2322 followed by
cement	10	1,2 $\Omega$ to 27 $\Omega$	10	E12	9	11,5 x 41	324 12 ...
		30 $\Omega$ to 300 $\Omega$	5	E12			324 32 ...
enamel		330 $\Omega$ to 3,3 k $\Omega$	5	E12			322 32 ...
cement	16	1,5 $\Omega$ to 2,7 $\Omega$	10	E12	5	11,5 x 62,5	324 10 ...
		3 $\Omega$ to 620 $\Omega$	5	E12			324 30 ...
enamel		680 $\Omega$ to 6,8 k $\Omega$	5	E12			322 30 ...
cement	25	2,7 $\Omega$ to 15 $\Omega$	10	E12	4	16 x 64	324 08 ...
		16 $\Omega$ to 820 $\Omega$	5	E12			324 28 ...
enamel		1 k $\Omega$ to 9,1 k $\Omega$	5	E12			322 28 ...
cement	40	4,7 $\Omega$ to 1,6 k $\Omega$	5	E12	2,5	16 x 103	324 26 ...
		1,8 k $\Omega$ to 18 k $\Omega$	5	E12			322 26 ...
cement	60	3 $\Omega$ to 2,2 k $\Omega$	5	E12	3	32 x 103	324 24 ...
		2,4 k $\Omega$ to 24 k $\Omega$	5	E12			322 24 ...
cement	100	6,8 $\Omega$ to 4,3 k $\Omega$	5	E12	1,5	32 x 165	324 23 ...
		4,7 k $\Omega$ to 47 k $\Omega$	5	E12			322 23 ...
enamel							
cement	160	10 $\Omega$ to 6,8 k $\Omega$	5	E12	1,5	44 x 165	324 22 ...
cement	250	16 $\Omega$ to 11 k $\Omega$	5	E12	1	44 x 256	324 21 ...

## COMPOSITION OF THE CATALOGUE NUMBER

The catalogue number in Table 3 is completed by inserting the resistance code; the first two figures of the resistance in  $\Omega$  followed by:

- 8 for  $R = 1,2$  to  $8,2 \Omega$
- 9 for  $R = 10$  to  $82 \Omega$
- 1 for  $R = 100$  to  $820 \Omega$
- 2 for  $R = 1$  to  $8,2 \Omega$
- 3 for  $R = 10$  to  $47 \Omega$

\* The adjustable contact short-circuits a number of windings. The maximum resistance loss has been given as a percentage of the nominal resistance. Nominal dissipation and nominal resistance values apply if no contact strap is connected.

\*\* Resistance values of the E24 series are available on request. See the table "Standard Series of values in a decade" at the back of the handbook.



## DEVELOPMENT SAMPLE DATA

This information is derived from development samples made available for evaluation. It does not necessarily imply that the device will go into regular production.

RC-01

## RESISTOR CHIP

### QUICK REFERENCE DATA

Resistance range	1 $\Omega$ to 10 M $\Omega$ and jumper (0 $\Omega$ ) E24, E12 and E6 series
Resistance tolerance	$\pm 5, \pm 10, \pm 20\%$
Temperature coefficient	$< \pm 200 \cdot 10^{-6}/K$
Abs. max. dissipation at $T_{amb} = 70^{\circ}C$	0,125 W
Maximum permissible voltage	200 V (r.m.s.)
Climatic category (IEC 68)	55/155/56
Basic specification	IEC 115-1
Stability after:	
load, 1000 h at $T_{amb} = 70^{\circ}C$	$\Delta R/R$ max. 1,5% + 0,2 $\Omega$
climatic tests	$\Delta R/R$ max. 1,5% + 0,2 $\Omega$
soldering	$\Delta R/R$ max. 1% + 0,05 $\Omega$
short time overload, max. 400 V	$\Delta R/R$ max. 2% + 0,2 $\Omega$

### APPLICATION

Resistor chips are used in a wide scale of equipment. Important considerations for using chip resistors are:

- decrease of size and mass of equipment
- reduction of assembly costs of equipment
- specific electrical requirements (such as h.f. characteristics).

The main application areas for resistor chips are:

TV (tuner), radio (hi-fi slim-line and portable), radio recorders, watches, video cameras, shavers, pocket calculators, instruments, telecommunication, medical equipment, military equipment and automotive industry.

### DESCRIPTION

On a high grade ceramic body (aluminium oxide) a metal glaze layer is screened. Depending on the composition of the metal glaze different resistance values can be obtained. On both ends a contact is made in such a way that optimum solderability is guaranteed. This is achieved by applying three layers. The resistive layer is covered with a protective coat.

**MECHANICAL DATA**

**Outlines**

Dimensions in mm

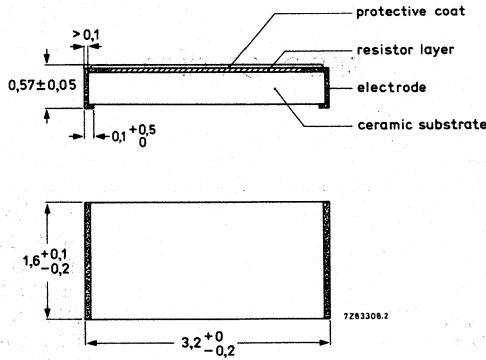

Fig. 1.

Mass (per 100) : 0,9 g

**Mounting**

This resistor chip is most suitable to be handled by automatic chip placement systems, due to its rectangular shape and the small tolerances on the dimensions. Chip placement can be done on ceramic substrates and printed circuit boards. The electrical connection to the circuit can be made by wave-soldering or reflow soldering. The electrodes guarantee a reliable contact. The protective coatings enable "face-down" mounting. Thanks to its robust construction the resistor chip can be immersed completely in a solder bath of 255 °C for one minute. By doing so it is possible to mount chip resistors on one side of a printed circuit board and other discrete components the other side.

**Marking**

The chips will not be marked. The marking is done on the packing. The marking includes resistance value, tolerance, code number, style, quantity, production period and an origin source code.

**Soldering**

Limiting conditions min. 230 °C, 2 s  
max. 250 °C, 60 s

Worst-case solder conditions:

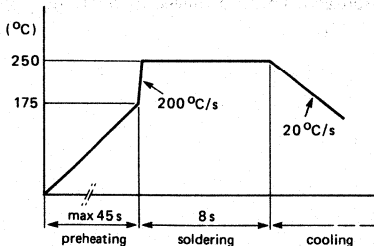

Fig. 2 Reflow soldering.

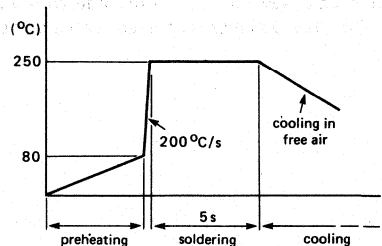

Fig. 3 Wave soldering.  
The resistors may be soldered twice according to this method if necessary.

7289653

**ELECTRICAL DATA**

Standard values of resistance and tolerance

Standard values of nominal resistance are taken from the E6 series for resistors with a tolerance of  $\pm 20\%$ ; from the E12 series for resistors with a tolerance of  $\pm 10\%$  and from the E24 series for resistors with a tolerance of  $\pm 5\%$  and  $\pm 10\%$ . The values of these series are given at the back of the Data Handbook and are according to IEC publication 63.

The limiting voltage (r.m.s.) for element and insulation is the maximum voltage that may be applied continuously to the resistor element or the insulation. See IEC publications 115-1 and 115-2. This voltage is 200 V.

Table 1

resistance range	tol. $\pm \%$	series	temperature coefficient $\cdot 10^{-6}/K$	catalogue number 2322 followed by		
				4000 on reel	1000 per bag	100 per bag
10 $\Omega$ to 1 M $\Omega$	5	E24	200	711 20...	715 50...	715 20...
1 $\Omega$ to 10 $\Omega$	10	E24		} 711 10...	715 40...	715 10...
10 $\Omega$ to 1 M $\Omega$	10	E12				
1 M $\Omega$ to 10 M $\Omega$	10	E24		711 00...	715 30...	715 00...
1 $\Omega$ to 10 M $\Omega$	20	E6				

The jumper has a maximum resistance  $R_{\max} = 50 \text{ m}\Omega$  at a rated current  $I_r = 2 \text{ A}$ . They are supplied 4000 on reel, catalogue number 2322 711 90001 or 100 per bag, catalogue number 2322 715 90001.

**COMPOSITION OF THE CATALOGUE NUMBER**

In the above-mentioned catalogue number, replace the first two dots by the first two digits of the resistance value. Replace the third dot by a figure according to the following table:

1 to 9,1 $\Omega$ : 8	10 to 91 k $\Omega$ : 3
10 to 91 $\Omega$ : 9	100 to 910 k $\Omega$ : 4
100 to 910 $\Omega$ : 1	1 to 9,1 M $\Omega$ : 5
1 to 9,1 k $\Omega$ : 2	10 M $\Omega$ : 6

## TESTS AND REQUIREMENTS

Essentially all tests are carried out according to the schedule of IEC publication 115-1. This means: rated temperature range  $-55$  to  $+155$  °C; damp heat (long term) 56 days (see IEC publication 115-2 clause 4.1). The tests are carried out along the lines of IEC publication 68, "Recommended basic climatic and mechanical robustness testing procedure for electronic components".

In Table 2 the tests and requirements are listed with reference to the relevant clauses of IEC publications 115-1 and 68: a short description of the test procedure is also given. In some instances deviations from the IEC recommendations were necessary for our method of specifying.

Table 2

IEC 115-1 clause	IEC 68 test method	test	procedure	requirements
19	T	soldering	unmounted chips completely immersed for $4 \pm 1$ s in a solder bath of $230 \pm 10$ °C	good tinning no damage $\Delta R$ max. $1\% + 0,05 \Omega$
20	Na	Rapid change of temp.	$\frac{1}{2}$ h $-55$ °C/ $\frac{1}{2}$ h $+155$ °C 5 cycles	$\Delta R$ max. 1,5% $+ 0,2 \Omega$
22	Fc	Vibration	frequency: 10-500 Hz; displacement 1,5 mm or acceleration 10g, three directions; total 6 h	no damage $\Delta R$ max. 0,5% $+ 0,05 \Omega$
21	Eb	Bump	3 x 1500 bumps in three directions; 40g	no damage, $\Delta R$ max. 0,5% $+ 0,05 \Omega$
23 23.2 23.3 23.4 23.5 23.6	Ba D Aa M D	Climatic sequence Dry heat Damp heat (accel.) 1st cycle Cold Low air pressure Damp heat (accel.) re- maining cycles	16 h; 155 °C  24 h; 55 °C; 95-100% R.H. 2 h; $-55$ °C 1 h; 8,5 kPa; 15-35 °C  5 days; 55 °C; 95-100% R.H.	         $R_{ins} = \text{min. } 1000 \text{ M}\Omega$ $\Delta R$ max. 1,5% $+ 0,2 \Omega$
24.2	Ca	Damp heat (steady state)	56 days; 40 °C; 90-95% R.H. dissipation $\leq 1,25$ mW	$R_{ins}$ min. 1000 M $\Omega$ $\Delta R$ max. 1,5% $+ 0,2 \Omega$
26.2	—	Endurance	1000 h; 70 °C; nominal dissipation	$\Delta R$ max. 1,5% $+ 0,2 \Omega$



IEC 115-1 clause	IEC 68 test method	test	procedure	requirements
9	—	insulation resistance	—	min. $10^4$ M $\Omega$
15	—	short time overload	room temp. dissipation 6,25 x 0,125 W (voltage not more than 2 x limiting voltage) 10 cycles 5 s on, 45 s off	$\Delta R$ max. 2% + 0,2 $\Omega$

**STANDARD PACKAGING**

1. Bandolier packaging, on reel  
 Quantity 4000 resistors per reel  
 Reel diameter 180 mm  
 Reel width 12,75 mm

2. Bulk packaging  
 Quantity 100 or 1000 per bag

DEVELOPMENT SAMPLE DATA

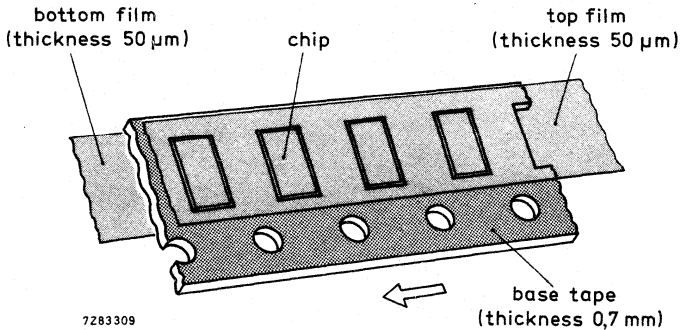
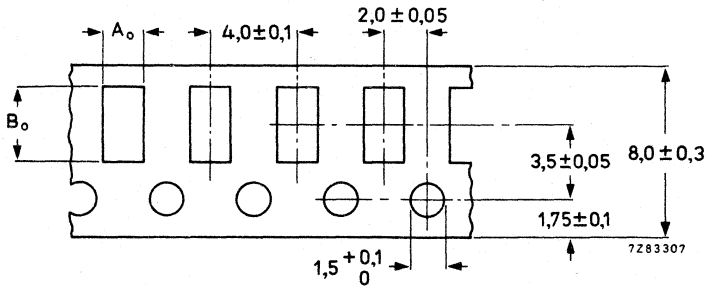

Fig. 4.



INDEX OF CATALOGUE NUMBERS

C





## INDEX OF CATALOGUE NUMBERS

catalogue number	page	catalogue number	page
2306 300	B99	2322 180	B16
301	B99	181	B23
302	B99	182	B30
		183	B23
330	B113	184	B23
331	B113	185	B30
332	B113		
333	B113	191	B81
335	B113	192	B81
		205	B36
2322 106	B5	206	B36
141	B60		
142	B60	210	B5
150	B45	211	B5
151	B45	212	B5
152	B45	213	B5
153	B45	214	B5
154	B45		
		241	B67
160	B53	242	B76
161	B53	243	B67
162	B53	244	B76
163	B53		
164	B53	321	B120
165	B53	322	B123
166	B53	323	B120
167	B53	324	B123
168	B53	329	B92
169	B53	330	B106
170	B53		
171	B53	711	B127
		715	B127



NOTES

NOTES

## **FIXED RESISTORS**

**A GENERAL**

**B FIXED RESISTORS**

**C INDEX OF CATALOGUE NUMBERS**



# STANDARD SERIES OF VALUES IN A DECADE

## for resistances and capacitances

according to IEC publication 63

E192	E96	E48	E192	E96	E48	E192	E96	E48	E192	E96	E48	E192	E96	E48
100	100	100	169	169	169	287	287	287	487	487	487	825	825	825
101			172			291			493			835		
102	102		174	174		294	294		499	499		845	845	
104			176			298			505			856		
105	105	105	178	178	178	301	301	301	511	511	511	866	866	866
106			180			305			517			876		
107	107		182	182		309	309		523	523		887	887	
109			184			312			530			898		
110	110	110	187	187	187	316	316	316	536	536	536	909	909	909
111			189			320			542			920		
113	113		191	191		324	324		549	549		931	931	
114			193			328			556			942		
115	115	115	196	196	196	332	332	332	562	562	562	953	953	953
117			198			336			569			965		
118	118		200	200		340	340		576	576		976	976	
120			203			344			583			988		
121	121	121	205	205	205	348	348	348	590	590	590			
123			208			352			597					
124	124		210	210		357	357		604	604				
126			213			361			612					
127	127	127	215	215	215	365	365	365	619	619	619	10	10	10
129			218			370			626			11		
130	130		221	221		374	374		634	634		12	12	
132			223			379			642			13		
133	133	133	226	226	226	383	383	383	649	649	649	15	15	15
135			229			388			657			16		
137	137		232	232		392	392		665	665		18	18	
138			234			397			673			20		
140	140	140	237	237	237	402	402	402	681	681	681	22	22	22
142			240			407			690			24		
143	143		243	243		412	412		698	698		27	27	
145			246			417			706			30		
147	147	147	249	249	249	422	422	422	715	715	715	33	33	33
149			252			427			723			36		
150	150		255	255		432	432		732	732		39	39	
152			258			437			741			43		
154	154	154	261	261	261	442	442	442	750	750	750	47	47	47
156			264			448			759			51		
158	158		267	267		453	453		768	768		56	56	
160			271			459			777			62		
162	162	162	274	274	274	464	464	464	787	787	787	68	68	68
164			277			470			796			75		
165	165		280	280		475	475		806	806		82	82	
167			284			481			816			91		

**Argentina:** PHILIPS ARGENTINA S.A., Div. Elcoma, Vedia 3892, 1430 BUENOS AIRES, Tel. 541-7141/7242/7343/7444/7545.  
**Australia:** PHILIPS INDUSTRIES HOLDINGS LTD., Elcoma Division, 67 Mars Road, LANE COVE, 2066, N.S.W., Tel. 427 08 88.  
**Austria:** ÖSTERREICHISCHE PHILIPS BAUELEMENTE Industrie G.m.b.H., Triester Str. 64, A-1101 WIEN, Tel. 62 91 11.  
**Belgium:** N.V. PHILIPS & MBLÉ ASSOCIATED, 9, rue du Pavillon, B-1030 BRUXELLES, Tel. (02) 242 74 00.  
**Brazil:** IBRAPE, Caixa Postal 7383, Av. Brigadeiro Faria Lima, 1735 SAO PAULO, SP, Tel. (011) 211 2600.  
**Canada:** PHILIPS ELECTRONICS LTD., Electron Devices Div., 601 Milner Ave., SCARBOROUGH, Ontario, M1B 1M8, Tel. 292-5161.  
**Chile:** PHILIPS CHILENA S.A., Av. Santa Maria 0760, SANTIAGO, Tel. 39-4001.  
**Colombia:** SADAPE S.A., P.O. Box 9805, Calle 13, No. 51 + 39, BOGOTA D.E. 1., Tel. 600 600.  
**Denmark:** MINIWATT A/S, Emdrupvej 115A, DK-2400 KØBENHAVN NV., Tel. (01) 69 16 22.  
**Finland:** OY PHILIPS AB, Elcoma Division, Kaivokatu 8, SF-00100 HELSINKI 10, Tel. 1 72 71.  
**France:** R.T.C. LA RADIOTECHNIQUE-COMPELEC, 130 Avenue Ledru Rollin, F-75540 PARIS 11, Tel. 355-44-99.  
**Germany:** VALVO, UB Bauelemente der Philips G.m.b.H., Valvo Haus, Burchardstrasse 19, D-2 HAMBURG 1, Tel. (040) 3296-1.  
**Greece:** PHILIPS S.A. HELLENIQUE, Elcoma Division, 52, Av. Syngrou, ATHENS, Tel. 9215111.  
**Hong Kong:** PHILIPS HONG KONG LTD., Elcoma Div., 15/F Philips Ind. Bldg., 24-28 Kung Yip St., KWAI CHUNG, Tel. (0)-24 51 21.  
**India:** PEICO ELECTRONICS & ELECTRICALS LTD., Ramon House, 169 Backbay Reclamation, BOMBAY 400020, Tel. 295144.  
**Indonesia:** P.T. PHILIPS RAILIN ELECTRONICS, Elcoma Div., Panim Bank Building, 2nd Fl., Jl. Jend. Sudirman, P.O. Box 223, JAKARTA, Tel. 716 13 13.  
**Ireland:** PHILIPS ELECTRICAL (IRELAND) LTD., Newstead, Clonskeagh, DUBLIN 14, Tel. 69 33 55.  
**Italy:** PHILIPS S.p.A., Sezione Elcoma, Piazza IV Novembre 3, I-20124 MILANO, Tel. 2-6994.  
**Japan:** NIHON PHILIPS CORP., Shuwa Shinagawa Bldg., 26-33 Takanawa 3-chome, Minato-ku, TOKYO (108), Tel. 448-5611.  
 (IC Products) SIGNETICS JAPAN, LTD., TOKYO, Tel. (03)230-1521.  
**Korea:** PHILIPS ELECTRONICS (KOREA) LTD., Elcoma Div., Philips House, 260-199 Itaewon-dong, Yongsan-ku, C.P.O. Box 3680, SEOUL, Tel. 794-4202.  
**Malaysia:** PHILIPS MALAYSIA SDN. BERHAD, Lot 2, Jalan 222, Section 14, Petaling Jaya, P.O.B. 2163, KUALA LUMPUR, Selangor, Tel. 77 44 11.  
**Mexico:** ELECTRONICA S.A. de C.V., Varsovia No. 36, MEXICO 6, D.F., Tel. 533-11-80.  
**Netherlands:** PHILIPS NEDERLAND, Marktgroep Elconco, Postbus 90050, 5600 PB EINDHOVEN, Tel. (040) 79 33 33.  
**New Zealand:** PHILIPS ELECTRICAL IND. LTD., Elcoma Division, 2 Wagener Place, St. Lukes, AUCKLAND, Tel. 894-160.  
**Norway:** NORSK A/S PHILIPS, Electronica Div., Sandstuveien 70, OSLO 6, Tel. 33 62 70.  
**Peru:** CADESA, Av. Alfonso Ugarte 1268, LIMA 5, Tel. 326070.  
**Philippines:** PHILIPS INDUSTRIAL DEV. INC., 2246 Pasong Tamo, P.O. Box 911, Makati Comm. Centre, MAKATI-RIZAL 3116, Tel. 86-89-51 to 59.  
**Portugal:** PHILIPS PORTUGESA S.A.R.L., Av. Eng. Duarte Pacheco 6, LISBOA 1, Tel. 68 31 21.  
**Singapore:** PHILIPS PROJECT DEV. (Singapore) PTE LTD., Elcoma Div., Lorong 1, Toa Payoh, SINGAPORE 1231, Tel. 25 38 811.  
**South Africa:** EDAC (Pty.) Ltd., 3rd Floor Rainer House, Upper Railway Rd. & Ove St., New Doornfontein, JOHANNESBURG 2001, Tel. 614-2362/9.  
**Spain:** MINIWATT S.A., Balmes 22, BARCELONA 7, Tel. 301 63 12.  
**Sweden:** A.B. ELCOMA, Lidingsvägen 50, S-11584 STOCKHOLM 27, Tel. 08/67 97 80.  
**Switzerland:** PHILIPS A.G., Elcoma Dept., Allmendstrasse 140-142, CH-8027 ZÜRICH, Tel. 01-488 22 11.  
**Taiwan:** PHILIPS TAIWAN LTD., 3rd Fl., San Min Building, 57-1, Chung Shan N. Rd, Section 2, P.O. Box 22978, TAIPEI, Tel. (02)-5631717.  
**Thailand:** PHILIPS ELECTRICAL CO. OF THAILAND LTD., 283 Silom Road, P.O. Box 961, BANGKOK, Tel. 233-6330-9.  
**Turkey:** TÜRK PHILIPS TICARET A.S., EMET Department, Inonu Cad. No. 78-80, ISTANBUL, Tel. 43 59 10.  
**United Kingdom:** MULLARD LTD., Mullard House, Torrington Place, LONDON WC1E 7HD, Tel. 01-580 6633.  
**United States:** (Active Devices & Materials) AMPEREX SALES CORP., Providence Pike, SLATERSVILLE, R.I. 02876, Tel. (401) 762-9000.  
 (Passive Devices) MEPCO/ELECTRA INC., Columbia Rd., MORRISTOWN, N.J. 07960, Tel. (201)539-2000.  
 (Passive Devices & Electromechanical Devices) CENTRALAB INC., 5855 N. Glen Park Rd., MILWAUKEE, WI 53201, Tel. (414)228-7380.  
 (IC Products) SIGNETICS CORPORATION, 811 East Arques Avenue, SUNNYVALE, California 94086, Tel. (408) 739-7700.  
**Uruguay:** LUZILECTRON S.A., Avda Rondeau 1576, piso 5, MONTEVIDEO, Tel. 91 43 21.  
**Venezuela:** IND. VENEZOLANAS PHILIPS S.A., Elcoma Dept., A. Ppal. de los Ruices, Edif. Centro Colgate, CARACAS, Tel. 36 05 11.

**For all other countries apply to:** N.V. PHILIPS, Electronic Components and Materials Division, Corporate Relations & Projects, Building BA/E3, 5600 MD EINDHOVEN, THE NETHERLANDS, Telex 35000, Tel. (040) 72 33 04.

A25

© 1982 N.V. Philips' Gloeilampenfabrieken

This information is furnished for guidance, and with no guarantees as to its accuracy or completeness; its publication conveys no licence under any patent or other right, nor does the publisher assume liability for any consequence of its use; specifications and availability of goods mentioned in it are subject to change without notice; it is not to be reproduced in any way, in whole or in part, without the written consent of the publisher.

Printed in The Netherlands